

Material:

Base: High temperature plastic UL 94V-0, Color Nature

Contact: Copper alloy

Tab: Copper alloy with Matte Tin plated

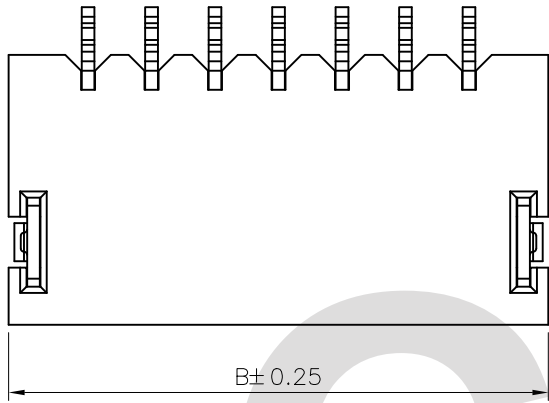

Ordering Code:

CI14 ** M 1 H R 0 -NH
 ① ② ③ ④ ⑤ ⑥ ⑦ ⑧

- ① Series No.
- ② No. of Circuits: 2~20 Pin
- ③ M= SMT Type Wafer
- ④ Plating: 1= 3.05μm(120μ") ~ 4.88μm(192μ")
Matte Tin over 1.27μm(50μ") Nickel

- ⑤ Type: H= Side Entry
- ⑥ Packing Options: R= Tape & Reel packing
- ⑦ Option: 0= Standard
- ⑧ Other option:
-NH= For Lead Free IR Processes and Halogen-Free

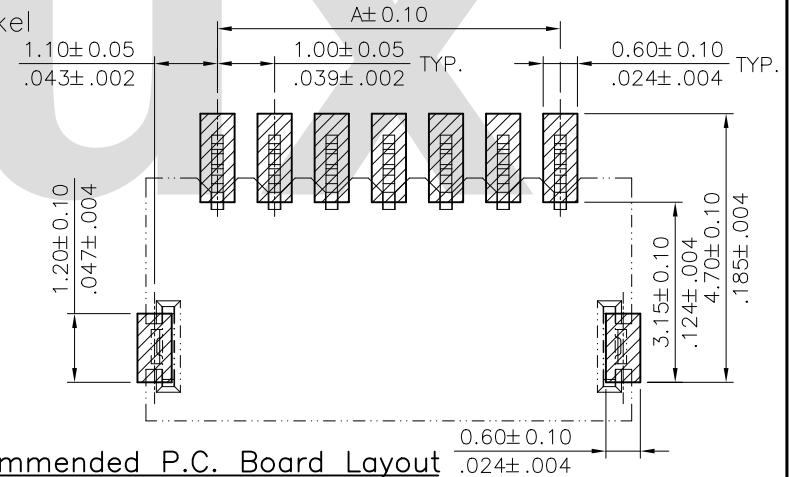
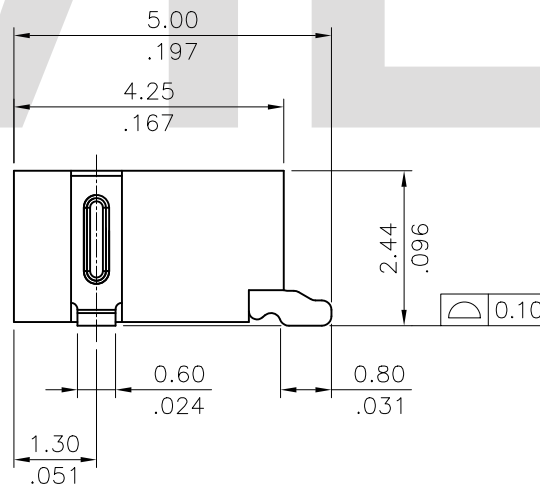
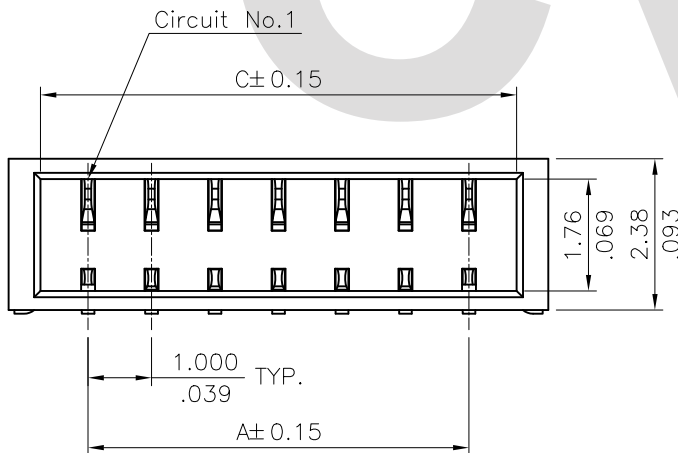

Recommended P.C. Board Layout

Halogen-Free

Lead Free Process

RoHS Compliant

⑤	Ellie	6/3-15'	ECNT115129/ECRH115027		DATE	UNIT: mm / inch	TITLE: 1.00MM(.079")	 瀚荃股份有限公司 CviLux Corporation
④	Sun	7/11-11'	ECR10039-2/ECN11060	DRAWN BY: Ellie	6/3-15'	TOLERANCE UNLESS OTHERWISE SPECIFIED	WIRE TO BOARD CONNECTOR	
③	Sun	11/25-09'	ECN09565	ENGINEER: Sun	6/4-15'	.X ± 0.25/.010 X' ± r'	MATERIAL:	
②	Eager	09/03-09'	ECN09452	CHECKED BY: Eisley	6/4-15'	.XX ± 0.15/.006 X' ±	FINISH:	
SYM	NAME	DATE	REVISIONS	APPROVED BY: Eisley	6/4-15'	.XXX ± 0.08/.003 .XX ±	DRAWING NO. CI1404SD	
								PART NO. CI14**M1HR0-NH
								SCALE 8 / 1
								SHEET 1 OF 2



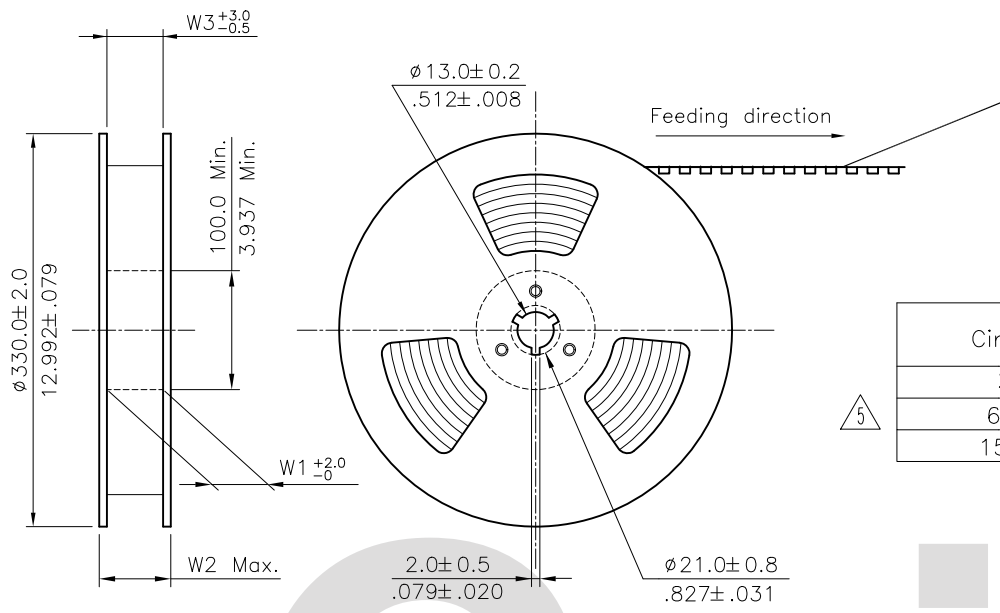

- NOTE :
- * Reel Material : Corrugated Paper
 - * Carrier Material : Clear, Conductive Polystyrene Alloy & Corrugated Paper
 - * Cover Tape Material : Polyester
 - * Cover Tape Peel Strength : 0.1N – 1.3N
 - * Carrier camber is within 1mm in 250mm
 - * All dimensions meet EIA-481-B requirements.
 - * Quantity : 2000 PCS/Reel

Circuits	Dimension					Packing (Reel/Caton)
	E	F	W1	W2	W3	
2~5	16.0	—	16.5	22.5	16.5	11
6~14	24.0	—	24.5	30.5	24.5	9
15~20	32.0	28.40	32.5	38.5	32.5	7

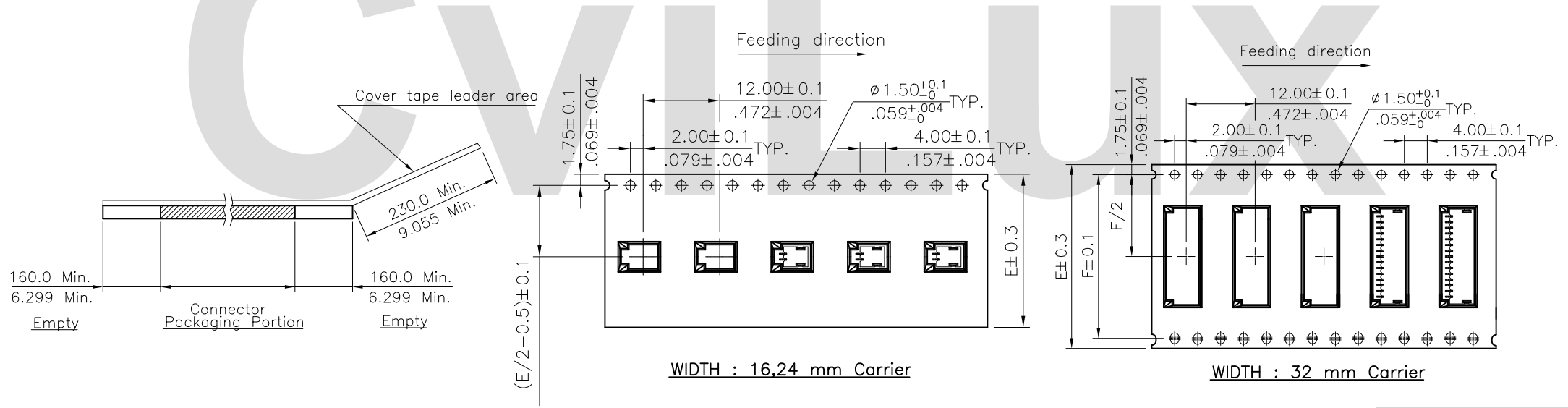

WIDTH : 16.24 mm Carrier

WIDTH : 32 mm Carrier

RoHS Compliant

REV	SYM	NAME	DATE	REVISIONS	APPROVED BY:	DATE	UNIT: mm / inch	TITLE: 1.25mm Side entry SMT Type Connector	MATERIAL:	FINISH:	DRAWING NO. CI1404SD	PART NO. CI14**M1HR0-NH	SHEET 2 OF 2
5	Ellie	6/3-15'	ECNT115129/ECRH115027										
4	Sun	7/11-11'	ECR10039-2/ECN11060		DRAWN BY: Ellie	6/3-15'	TOLERANCE UNLESS OTHERWISE SPECIFIED						
3	Sun	11/25-09'	ECN09565		ENGINEER: Sun	6/4-15'	.X ±	X' ± ' "					
2	Eager	09/03-09'	ECN09452		CHECKED BY: Eisley	6/4-15'	.XX ±	.X ±					
					APPROVED BY: Eisley	6/4-15'	.XXX ±	.XX ±					

