

Material:
 Insulator: Glass filled Polyester UL 94V-0
 Shell: Steel, Tin plated as standard
 High power Contact:
 Brass with Gold plated

Ordering Code

C8W8 S P V 3 0 1 20 D00
 ① ② ③ ④ ⑤ ⑥ ⑦ ⑧ ⑨

- ① Series No.
- ② Connector Type: S= Receptacle
- ③ Contact type: P= High Power Contact
- ④ Contact tail style: V= Straight Dip type
- ⑤ High power contact plating:
 2= Gold flash plated over Nickel
 3= 15 μ " Gold plated over Nickel
 4= 30 μ " Gold plated over Nickel
 5= 50 μ " Gold plated over Nickel
- ⑥ Singal contact plating:
 0= Without singal contact
- ⑦ Insulator color: 1= Black, 6= Green
- ⑧ Performance: 20= 20A
- ⑨ Mounting Style:
 000= With ϕ 3.05mm holes on shell
 B00= Riveted #4-40 UNC open nuts on front shell
 C00= Riveted #4-40 UNC open nuts on rear shell
 D00= Riveted #4-40 UNC ground stand-off on rear shell(standard)

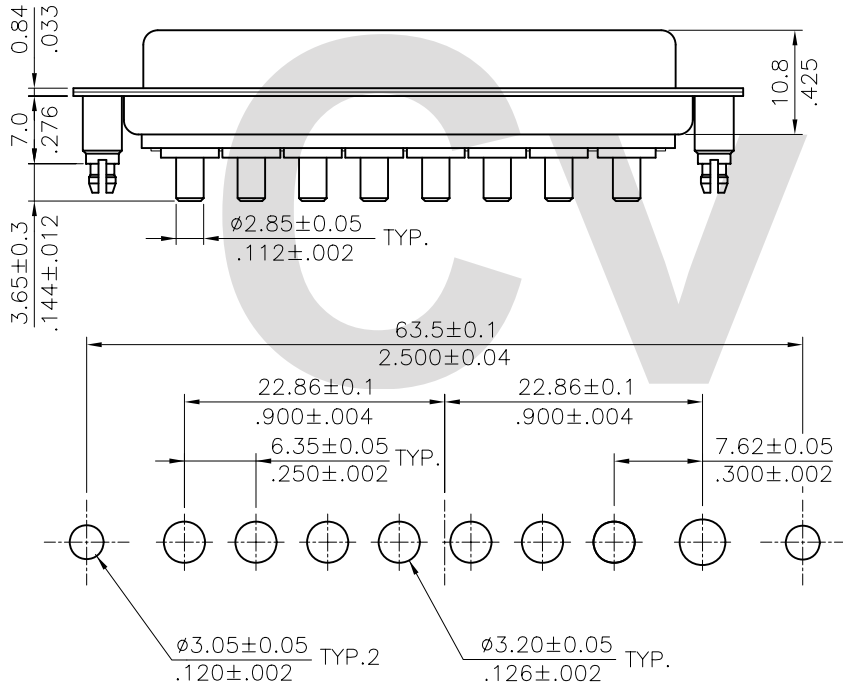

Recommended P.C Board Layout

Mounting Style

Code		000	Code		B00	Code		C00	Code		D00
					DIM. L= 4.0mm			DIM. L= 4.0mm			DIM. L= 7.0mm

RoHS Compliant

4					DATE	UNIT: mm / inch	TITLE: C8W8 20A HIGH POWER FEMALE D-SUB CONNECTOR (TOP ENTRY BOARD MOUNT TYPE)		
3				DRAWN BY: Rita	10/18-01'	TOLERANCE UNLESS OTHERWISE SPECIFIED			
2				ENGINEER: David	10/19-01'	.X ± 0.30/012			X' ± 1'
1				CHECKED BY: David	10/19-01'	.XX ± 0.20/008			.X' ±
SYM	NAME	DATE	REVISIONS	APPROVED BY: Alex	10/19-01'	.XXX ± 0.10/004	.XX' ±	FINISH:	



瀚荃股份有限公司
CviLux Corporation

DRAWING NO.	C8W808SB	PART NO.	C8W8SPV*0*20*00
SCALE	2 / 1	SHEET	1 OF 1