

A = 2.54 \* No. of Spaces  
 B = A + 2.36  
 \* Available in 4 through 80 circuits

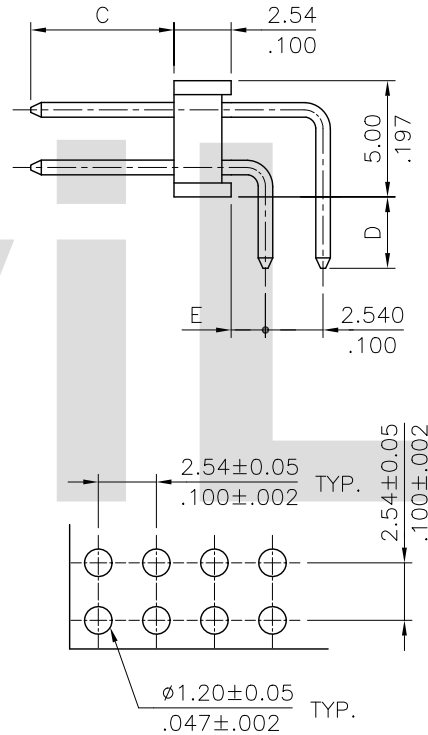

Recommended P.C. Board Layout

Notes:

- \* Material:  
Contact: Brass
- \* Pin overall Length 30.0mm Max.

Ordering Code

CH81    \*\*    \*    H    A    \*\*    -NH  
 ①    ②    ③    ④    ⑤    ⑥    ⑦

- ① Series No.
- ② No. of Circuits
- ③ Plating code:  
 1= 3.05µm(120µ") Min. Matte Tin over 0.76µm(30µ") Nickel  
 2= Gold flash plated over 1.27µm(50µ") Nickel
- ④ H= Right angle
- ⑤ Color: A= Nylon 6T UL 94V-0, Color Black
- △⑥ Pin Length Option Code:  
See Table PDF. File No. CH8102T
- ⑦ NH= For Lead Free IR Processes and Halogen-Free

Halogen-Free

Lead Free Process

RoHS Compliant

△4				 <b>2010.08.10</b> <b>ISSUED</b>		DATE	UNIT: mm / inch	TITLE: 2.54MM(.100") RIGHT ANGLE DUAL ROW BOARD MOUNT PIN HEADER	 瀚荃股份有限公司 CviLux Corporation		
△3			DRAWN BY: Karen		7/19-10'	TOLERANCE UNLESS OTHERWISE SPECIFIED		MATERIAL:			
△2			ENGINEER: Eisley		7/22-10'	.X ± 0.30/.012	X* ± 1"	FINISH:			
△1	Karen	7/19-10'	CHECKED BY: David		7/22-10'	.XX ± 0.20/.008	.X* ±				
SYM	NAME	DATE	REVISIONS	APPROVED BY: David	7/22-10'	.XXX ± 0.10/.004	.XX* ±	DRAWING NO. CH8162SB	PART NO. CH81***HA**-NH		
								SCALE	3 / 1	SHEET	1 OF 1