

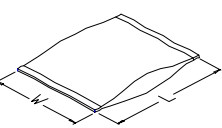
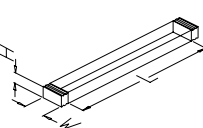
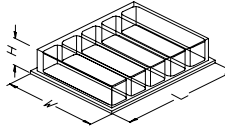
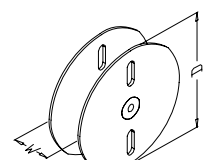
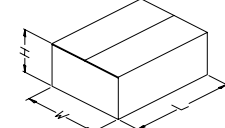
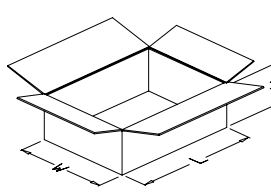
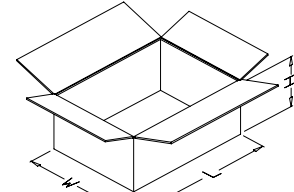

SERIES OR P/N	CIRCUITS	PACKING METHOD CODE	INNER PACKING NO.	INNER PACKING SIZE (CM)			INNER PACKING QTY	INSIDE CARTON NO.	INSIDE CARTON SIZE (CM)			PCS / INSIDE CARTON	CARTON NO.	CARTON SIZE (CM)			PCS / CARTON	G.W REF. (KG)
				L/D	W	H			L	W	H			L	W	H		
CH7204*V100	4	G		10.80	4.00	4.30	152				18240				36480			
CH7206*V100	6	G		10.80	4.00	4.30	101				12120				24240			
CH7208*V100	8	G		10.80	4.00	4.30	76				9120				18240			
CH7210*V100	10	G		10.80	4.00	4.30	61				7320				14640			
CH7212*V100	12	G		10.80	4.00	4.30	51				6120				12240			
CH7214*V100	14	G		10.80	4.00	4.30	43				5160				10320			
CH7216*V100	16	G		10.80	4.00	4.30	38				4560				9120			
CH7218*V100	18	G		10.80	4.00	4.30	33				3960				7920			
CH7220*V100	20	G		10.80	4.00	4.30	30				3600				7200			
CH7222*V100	22	G		10.80	4.00	4.30	27				3240				6480			
CH7224*V100	24	G		10.80	4.00	4.30	25				3000				6000			
CH7226*V100	26	G		10.80	4.00	4.30	23				2760				5520			
CH7228*V100	28	G		10.80	4.00	4.30	21				2520				5040			
CH7230*V100	30	G		10.80	4.00	4.30	20				2400				4800			
CH7232*V100	32	G		10.80	4.00	4.30	19				2280				4560			
CH7234*V100	34	G		10.80	4.00	4.30	17				2040				4080			
CH7236*V100	36	G		10.80	4.00	4.30	16				1920				3840			
CH7238*V100	38	G		10.80	4.00	4.30	16				1920				3840			
CH7240*V100	40	G		10.80	4.00	4.30	15				1800				3600			
CH7242*V100	42	G		10.80	4.00	4.30	14				1680				3360			
CH7244*V100	44	G		10.80	4.00	4.30	13				1560				3120			
CH7246*V100	46	G		10.80	4.00	4.30	13				1560				3120			
CH7248*V100	48	G		10.80	4.00	4.30	12				1440				2880			
CH7250*V100	50	G		10.80	4.00	4.30	12				1440				2880			

**PACKING METHOD (包裝方式) :**

<p><b>1</b> PVC BAG (塑膠袋) SIZE = L * W</p> 	<p><b>2</b> TUBE (塑膠管) SIZE = L * W * H</p> 	<p><b>3</b> PVC TRAY (塑膠盒) SIZE = L * W * H</p> 	<p><b>4</b> REEL (紙盤) SIZE = D * W</p> 	<p><b>5</b> BOX (內紙盒) SIZE = L * W * H</p> 	<p><b>6</b> INSIDE CARTON (內箱) SIZE = L * W * H</p> 	<p><b>7</b> OUTSIDE CARTON (外箱) SIZE = L * W * H</p> 	<p><b>PACKING METHOD CODE (包裝方式代碼) :</b></p> <ul style="list-style-type: none"> <li><input type="checkbox"/> A = 1 → 7</li> <li><input type="checkbox"/> B = 2 → 7</li> <li><input type="checkbox"/> C = 3 → 7</li> <li><input type="checkbox"/> D = 4 → 7</li> <li><input type="checkbox"/> E = 5 → 7</li> <li><input type="checkbox"/> F = 1 → 6 → 7</li> <li><input checked="" type="checkbox"/> G = 2 → 6 → 7</li> <li><input type="checkbox"/> H = 3 → 6 → 7</li> </ul>
---	---	---	--	--	---	--	--

核 准： SMITH                      審 核： RITA                      製 訂： PETER



SERIES OR P/N	CIRCUITS	PACKING METHOD CODE	INNER PACKING NO.	INNER PACKING SIZE (CM)			INNER PACKING QTY	INSIDE CARTON NO.	INSIDE CARTON SIZE (CM)			PCS / INSIDE CARTON	CARTON NO.	CARTON SIZE (CM)			PCS / CARTON	G.W REF. (KG)
				L/D	W	H			L	W	H			L	W	H		
CH7252*V100	52	G		10.80	4.00	4.30	11				1320				2640			
CH7254*V100	54	G		10.80	4.00	4.30	11				1320				2640			
CH7256*V100	56	G		10.80	4.00	4.30	10				1200				2400			
CH7258*V100	58	G		10.80	4.00	4.30	10				1200				2400			
CH7260*V100	60	G		10.80	4.00	4.30	10				1200				2400			
CH7262*V100	62	G		10.80	4.00	4.30	9				1080				2160			
CH7264*V100	64	G		10.80	4.00	4.30	9				1080				2160			
CH7266*V100	66	G		10.80	4.00	4.30	9				1080				2160			
CH7268*V100	68	G		10.80	4.00	4.30	8				960				1920			
CH7270*V100	70	G		10.80	4.00	4.30	8				960				1920			
CH7272*V100	72	G		10.80	4.00	4.30	8				960				1920			
CH7274*V100	74	G		10.80	4.00	4.30	8				960				1920			
CH72760*V100	76	G		10.80	4.00	4.30	8				960				1920			
CH7278*V100	78	G		10.80	4.00	4.30	7				840				1680			
CH7280*V100	80	G		10.80	4.00	4.30	7				840				1680			

PACKING METHOD (包裝方式) :

**1** PVC BAG  
(塑膠袋)  
SIZE = L \* W

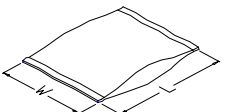

**2** TUBE  
(塑膠管)  
SIZE = L \* W \* H

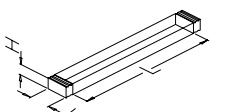

**3** PVC TRAY  
(塑膠盒)  
SIZE = L \* W \* H

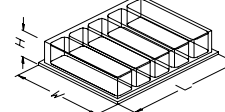

**4** REEL  
(紙盤)  
SIZE = D \* W

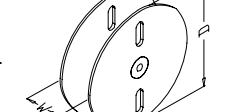

**5** BOX  
(內紙盒)  
SIZE = L \* W \* H

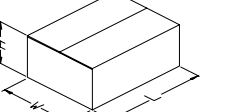

**6** INSIDE CARTON  
(內箱)  
SIZE = L \* W \* H



**7** OUTSIDE CARTON  
(外箱)  
SIZE = L \* W \* H



PACKING METHOD CODE (包裝方式代碼) :

- A = 1 → 7
- B = 2 → 7
- C = 3 → 7
- D = 4 → 7
- E = 5 → 7
- F = 1 → 6 → 7
- G = 2 → 6 → 7
- H = 3 → 6 → 7

核准： SMITH

審核： RITA

製訂： PETER