

FOR 2 Circuits

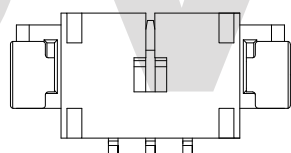

FOR 3 Circuits

A = 1.25 x No. of Spaces

B = A + 6.1

C = A + 1.9

* Available in 2 through 15 circuits

ORDERING CODE:

CI44 ** M 1 H 00
 ① ② ③ ④ ⑤ ⑥

- ① SERIES NO.:
- ② NO. OF CIRCUITS: 02 TO 15
- ③ CONTACTS TYPE: M= SMT
- ④ PLATING OPTION:
1= TIN OVER NICKEL PLATED
- ⑤ TAIL STYLE: H= RIGHT ANGLE
- ⑥ OPTION: 00= STANDARD(TUBE PACKING)
R0= TAPE & REEL PACKING

Note:

* Material :

Insulation:

Nylon 46+40% G.F UL 94V-0

Color Nature(Ivory)

Contact : Phosphor Bronze

Fixed Tab : Brass with Tin Plated

* Recommended mating part:

Housing : CI44**S0000

Terminal : CI44T011PP0

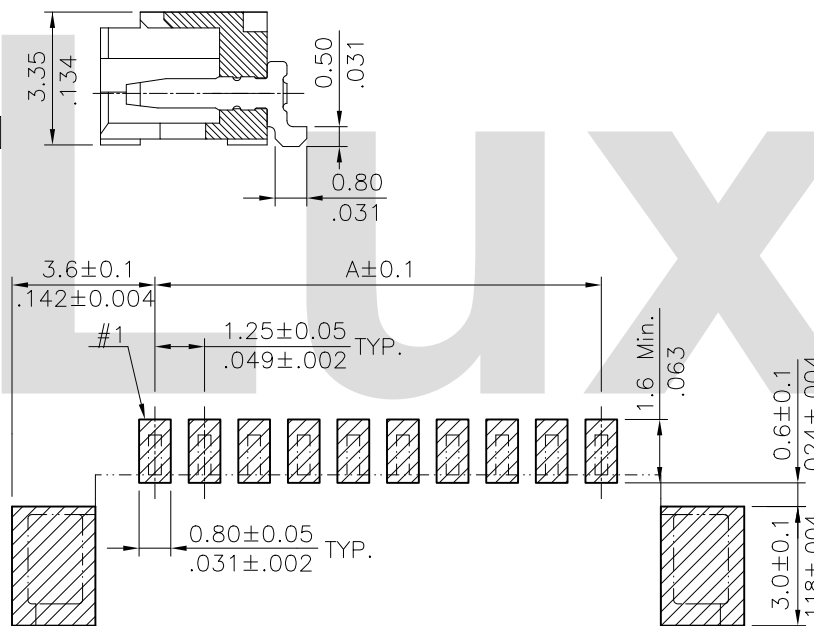

Sold Pad Pattern

Tin-Lead Process

RoHS Compliant

△10	Karen	12/09-14'	ECNT114252/ECRT114090	 2015.01.16 ISSUED	DATE	UNIT: mm / inch	TITLE: 1.25MM(.049")	 瀚荃股份有限公司 CviLux Corporation	
△9	Enya	7/26-12'	ECN12176-0 / ECR12061-1		DRAWN BY: Karen	12/25-14'	TOLERANCE UNLESS OTHERWISE SPECIFIED		RIGHT ANGLE SMT TYPE HEADER
△8	Sun	5/26-11'	ECN11071/ECR11010-1		ENGINEER: Sun	12/26-14'	.X ± 0.25/.010 X' ± 1'		MATERIAL:
△7	Sandy	6/18-08'	ECN08287		CHECKED BY: Eisley	12/29-14'	.XX ± 0.15/.006 X' ±		FINISH:
SYM	NAME	DATE	REVISIONS		APPROVED BY: Eisley	12/29-14'	.XXX ± 0.08/.003 .XX' ±		
			DRAWING NO. CI4405SQ	PART NO. CI44**M1H*0		SCALE 5 / 1		SHEET 1 OF 2	

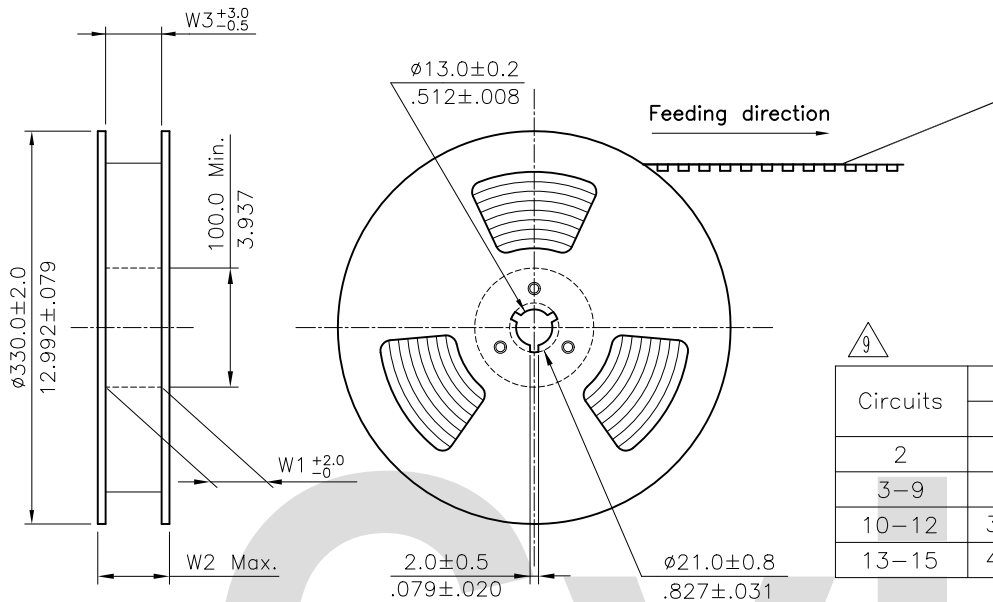

NOTE :

- ⚠️ * Reel Material : Corrugated Paper
- * Carrier Material : Clear, Conductive Polystyrene Alloy
- * Cover Tape Material : Polyester
- * Cover Tape Peel Strength : 0.1N – 1.3N
- * Carrier camber is within 1mm in 100mm
- * All dimensions meet EIA-481-2 & EIA-481-3 requirements.
- * Quantity : 1400 PCS/Reel

Circuits	Dimension					Packing (Reel/Caton)
	E	F	W1	W2	W3	
2	16.0(.630)	---	16.5(.650)	22.5(.886)	16.5(.650)	11
3-9	24.0(.945)	---	24.5(.965)	30.5(1.201)	24.5(.965)	9
10-12	32.0(1.260)	28.40(1.118)	32.5(1.280)	38.5(1.516)	32.5(1.280)	7
13-15	44.0(1.732)	40.40(1.591)	44.5(1.752)	50.5(1.988)	44.5(1.752)	5

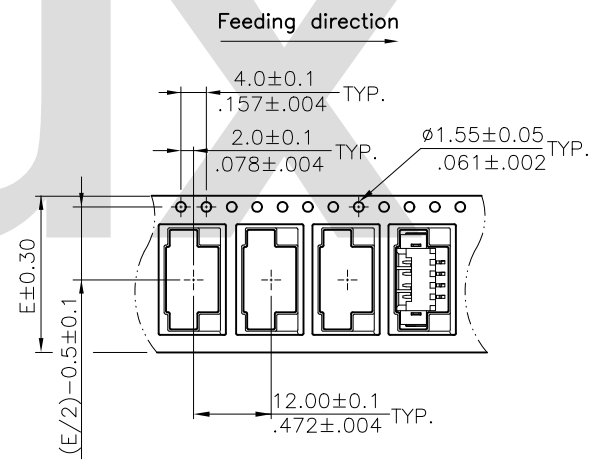
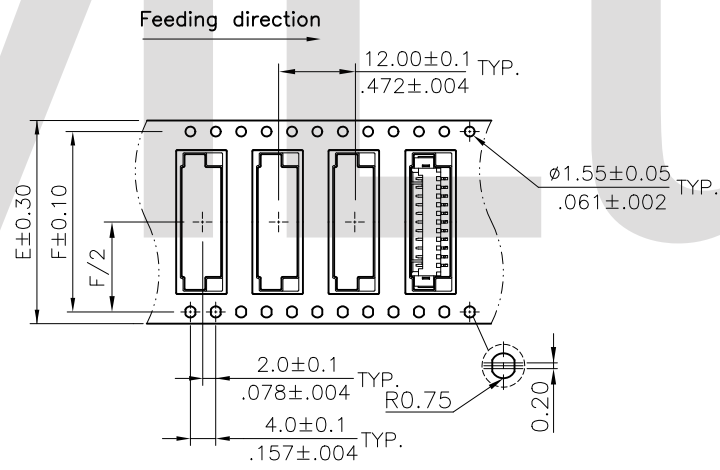
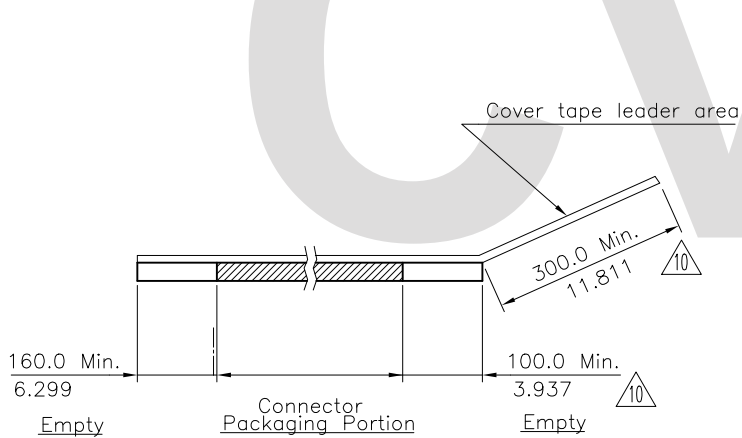

WIDTH : 32.44 mm Carrier

WIDTH : 16.24 mm Carrier

RoHS Compliant

SYM	NAME	DATE	REVISIONS	APPROVED BY:	DATE	UNIT: mm / inch	TOLERANCE UNLESS OTHERWISE SPECIFIED	TITLE: 1.25MM(.049") RIGHT ANGLE SMT TYPE HEADER	MATERIAL:	FINISH:	DRAWING NO. CI4405SQ	PART NO. CI44**M1H*O	SCALE	SHEET 2 OF 2
10	Karen	12/09-14'	ECNT114252/ECRT114090											
9	Enya	7/26-12'	ECN12176-0 / ECR12061-1											
8	Sun	5/26-11'	ECN11071/ECR11010-1											
7	Sandy	6/18-08'	ECN08287											

CIVILUX CORP
2015.01.16
ISSUED

瀚荃股份有限公司
CviLux Corporation