

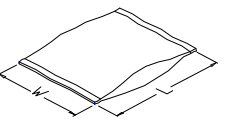

SERIES OR P/N	CIRCUITS	PACKING METHOD CODE	INNER PACKING NO.	INNER PACKING SIZE (CM)			INNER PACKING QTY	INSIDE CARTON NO.	INSIDE CARTON SIZE (CM)			PCS / INSIDE CARTON	CARTON NO.	CARTON SIZE (CM)			PCS / CARTON	G.W REF. (KG)
				L/D	W	T			L	W	H			L	W	H		
CH3101*V*00	1	C	PACK-PBC058-C	25.0	16.0	0.012	5000	PACK-PTC069/70-C/H	32.00	25.00	6.00	20000	PACK-CTC002-C	34.5	26.0	25.3	80000	0.44
CH3102*V*00	2	C	PACK-PBC058-C	25.0	16.0	0.012	5000	PACK-PTC069/70-C/H	32.00	25.00	6.00	20000	PACK-CTC002-C	34.5	26.0	25.3	80000	9.17
CH3103*V*00	3	C	PACK-PBC058-C	25.0	16.0	0.012	2000	PACK-PTC069/70-C/H	32.00	25.00	6.00	4000	PACK-CTC002/-C	34.50	26.00	25.30	40000	0.44
CH3104*V*00	4	C	PACK-PBC058-C	25.0	16.0	0.012	2000	PACK-PTC069/70-C/H	32.00	25.00	6.00	4000	PACK-CTC002/-C	34.50	26.00	25.30	16000	0.44
CH3105*V*00	5	C	PACK-PBC058-C	25.0	16.0	0.012	2000	PACK-PTC069/70-C/H	32.00	25.00	6.00	4000	PACK-CTC002/-C	34.50	26.00	25.30	16000	0.44
CH3106*V*00	6	C	PACK-PBC058-C	25.0	16.0	0.012	2000	PACK-PTC069/70-C/H	32.00	25.00	6.00	4000	PACK-CTC002/-C	34.50	26.00	25.30	16000	0.44
CH3107*V*00	7	C	PACK-PBC058-C	25.0	16.0	0.012	1000	PACK-PTC069/70-C/H	32.00	25.00	6.00	2000	PACK-CTC002/-C	34.50	26.00	25.30	8000	0.44
CH3108*V*00	8	C	PACK-PBC058-C	25.0	16.0	0.012	1000	PACK-PTC069/70-C/H	32.00	25.00	6.00	2000	PACK-CTC002/-C	34.50	26.00	25.30	8000	0.44
CH3109*V*00	9	C	PACK-PBC058-C	25.0	16.0	0.012	1000	PACK-PTC069/70-C/H	32.00	25.00	6.00	2000	PACK-CTC002/-C	34.50	26.00	25.30	8000	0.44
CH3110*V*00	10	C	PACK-PBC058-C	25.0	16.0	0.012	1000	PACK-PTC069/70-C/H	32.00	25.00	6.00	2000	PACK-CTC002/-C	34.50	26.00	25.30	8000	0.44
CH3111*V*00	11	C	PACK-PBC058-C	25.0	16.0	0.012	1000	PACK-PTC069/70-C/H	32.00	25.00	6.00	2000	PACK-CTC002/-C	34.50	26.00	25.30	8000	0.44
CH3112*V*00	12	C	PACK-PBC058-C	25.0	16.0	0.012	1000	PACK-PTC069/70-C/H	32.00	25.00	6.00	2000	PACK-CTC002/-C	34.50	26.00	25.30	8000	0.44
CH3113*V*00	13	C	PACK-PBC058-C	25.0	16.0	0.012	1000	PACK-PTC069/70-C/H	32.00	25.00	6.00	2000	PACK-CTC002/-C	34.50	26.00	25.30	8000	0.44
CH3114*V*00	14	C	PACK-PBC058-C	25.0	16.0	0.012	1000	PACK-PTC069/70-C/H	32.00	25.00	6.00	2000	PACK-CTC002/-C	34.50	26.00	25.30	8000	0.44
CH3115*V*00	15	C	PACK-PBC058-C	25.0	16.0	0.012	1000	PACK-PTC069/70-C/H	32.00	25.00	6.00	2000	PACK-CTC002/-C	34.50	26.00	25.30	8000	0.44
CH3116*V*00	16	C	PACK-PBC058-C	25.0	16.0	0.012	500	PACK-PTC069/70-C/H	32.00	25.00	6.00	1000	PACK-CTC002/-C	34.50	26.00	25.30	4000	0.44
CH3117*V*00	17	C	PACK-PBC058-C	25.0	16.0	0.012	500	PACK-PTC069/70-C/H	32.00	25.00	6.00	1000	PACK-CTC002/-C	34.50	26.00	25.30	4000	0.44
CH3118*V*00	18	C	PACK-PBC058-C	25.0	16.0	0.012	500	PACK-PTC069/70-C/H	32.00	25.00	6.00	1000	PACK-CTC002/-C	34.50	26.00	25.30	4000	0.44
CH3119*V*00	19	C	PACK-PBC058-C	25.0	16.0	0.012	500	PACK-PTC069/70-C/H	32.00	25.00	6.00	1000	PACK-CTC002/-C	34.50	26.00	25.30	4000	0.44
CH3120*V*00	20	C	PACK-PBC058-C	25.0	16.0	0.012	500	PACK-PTC069/70-C/H	32.00	25.00	6.00	1000	PACK-CTC002/-C	34.50	26.00	25.30	4000	0.44
CH3121*V*00	21	C	PACK-PBC058-C	25.0	16.0	0.012	500	PACK-PTC069/70-C/H	32.00	25.00	6.00	1000	PACK-CTC002/-C	34.50	26.00	25.30	4000	0.44
CH3122*V*00	22	C	PACK-PBC058-C	25.0	16.0	0.012	500	PACK-PTC069/70-C/H	32.00	25.00	6.00	1000	PACK-CTC002/-C	34.50	26.00	25.30	4000	0.44
CH3123*V*00	23	C	PACK-PBC058-C	25.0	16.0	0.012	500	PACK-PTC069/70-C/H	32.00	25.00	6.00	1000	PACK-CTC002/-C	34.50	26.00	25.30	4000	0.44
CH3124*V*00	24	C	PACK-PBC058-C	25.0	16.0	0.012	500	PACK-PTC069/70-C/H	32.00	25.00	6.00	1000	PACK-CTC002/-C	34.50	26.00	25.30	4000	0.44
CH3125*V*00	25	C	PACK-PBC058-C	25.0	16.0	0.012	500	PACK-PTC069/70-C/H	32.00	25.00	6.00	1000	PACK-CTC002/-C	34.50	26.00	25.30	4000	0.44
CH3126*V*00	26	C	PACK-PBC058-C	25.0	16.0	0.012	500	PACK-PTC069/70-C/H	32.00	25.00	6.00	1000	PACK-CTC002/-C	34.50	26.00	25.30	4000	0.44
CH3127*V*00	27	C	PACK-PBC058-C	25.0	16.0	0.012	500	PACK-PTC069/70-C/H	32.00	25.00	6.00	1000	PACK-CTC002/-C	34.50	26.00	25.30	4000	0.44

PACKING METHOD (包裝方式) :

<p>1 PVC BAG (塑膠袋) SIZE = L * W</p> 	<p>2 TUBE (塑膠管) SIZE = L * W * H</p> 	<p>3 PVC TRAY (塑膠盒) SIZE = L * W * H</p> 	<p>4 REEL (紙盤) SIZE = D * W</p> 	<p>5 BOX (內紙盒) SIZE = L * W * H</p> 	<p>6 INSIDE CARTON (內箱) SIZE = L * W * H</p> 	<p>7 OUTSIDE CARTON (外箱) SIZE = L * W * H</p> 	<p>PACKING METHOD CODE (包裝方式代碼):</p> <ul style="list-style-type: none"> <input type="checkbox"/> A = 1 → 7 <input type="checkbox"/> B = 2 → 7 <input checked="" type="checkbox"/> C = 1+3 → 7 <input type="checkbox"/> D = 4 → 7 <input type="checkbox"/> E = 5 → 7 <input checked="" type="checkbox"/> F = 1 → 6 → 7 <input type="checkbox"/> G = 2 → 6 → 7 <input type="checkbox"/> H = 3 → 6 → 7
---	---	---	---	--	---	--	---

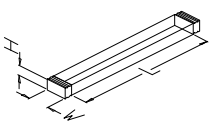
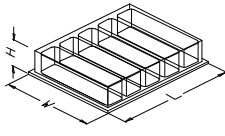
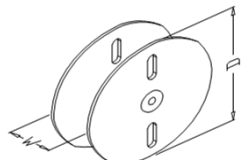
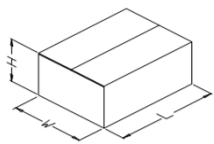
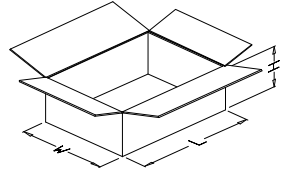
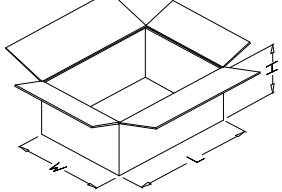

瀚荃股份有限公司
CviLux Corporation
PACKING STANDARD

製訂日期：2014/11/06

SERIES OR P/N	CIRCUITS	PACKING METHOD CODE	INNER PACKING NO.	INNER PACKING SIZE (CM)			INNER PACKING QTY	INSIDE CARTON NO.	INSIDE CARTON SIZE (CM)			PCS / INSIDE CARTON	CARTON NO.	CARTON SIZE (CM)			PCS / CARTON	G.W REF. (KG)
				L/D	W	T			L	W	H			L	W	H		
CH3128*V*00	28	C	PACK-PBC058-C	25.0	16.0	0.012	500	PACK-PTC069/70-C/H	32.00	25.00	6.00	1000	PACK-CTC002/-C	34.50	26.00	25.30	4000	10.46
CH3129*V*00	29	C	PACK-PBC058-C	25.0	16.0	0.012	500	PACK-PTC069/70-C/H	32.00	25.00	6.00	1000	PACK-CTC002/-C	34.50	26.00	25.30	4000	10.81
CH3130*V*00	30	C	PACK-PBC058-C	25.0	16.0	0.012	500	PACK-PTC069/70-C/H	32.00	25.00	6.00	1000	PACK-CTC002/-C	34.50	26.00	25.30	4000	11.15
CH3131*V*00	31	C	PACK-PBC058-C	25.0	16.0	0.012	250	PACK-PTC069/70-C/H	32.00	25.00	6.00	1000	PACK-CTC002/-C	34.50	26.00	25.30	4000	6.23
CH3132*V*00	32	C	PACK-PBC058-C	25.0	16.0	0.012	250	PACK-PTC069/70-C/H	32.00	25.00	6.00	1000	PACK-CTC002/-C	34.50	26.00	25.30	4000	6.36
CH3133*V*00	33	C	PACK-PBC058-C	25.0	16.0	0.012	250	PACK-PTC069/70-C/H	32.00	25.00	6.00	1000	PACK-CTC002/-C	34.50	26.00	25.30	4000	6.54
CH3134*V*00	34	C	PACK-PBC058-C	25.0	16.0	0.012	250	PACK-PTC069/70-C/H	32.00	25.00	6.00	1000	PACK-CTC002/-C	34.50	26.00	25.30	4000	6.70
CH3135*V*00	35	C	PACK-PBC058-C	25.0	16.0	0.012	250	PACK-PTC069/70-C/H	32.00	25.00	6.00	1000	PACK-CTC002/-C	34.50	26.00	25.30	4000	10.98
CH3136*V*00	36	C	PACK-PBC058-C	25.0	16.0	0.012	250	PACK-PTC069/70-C/H	32.00	25.00	6.00	1000	PACK-CTC002/-C	34.50	26.00	25.30	4000	11.74
CH3137*V*00	37	C	PACK-PBC058-C	25.0	16.0	0.012	250	PACK-PTC069/70-C/H	32.00	25.00	6.00	1000	PACK-CTC002/-C	34.50	26.00	25.30	4000	11.58
CH3138*V*00	38	C	PACK-PBC058-C	25.0	16.0	0.012	250	PACK-PTC069/70-C/H	32.00	25.00	6.00	1000	PACK-CTC002/-C	34.50	26.00	25.30	4000	11.90
CH3139*V*00	39	C	PACK-PBC058-C	25.0	16.0	0.012	250	PACK-PTC069/70-C/H	32.00	25.00	6.00	1000	PACK-CTC002/-C	34.50	26.00	25.30	4000	12.22
CH3140*V*00	40	C	PACK-PBC058-C	25.0	16.0	0.012	250	PACK-PTC069/70-C/H	32.00	25.00	6.00	1000	PACK-CTC002/-C	34.50	26.00	25.30	4000	12.42
<p>注：CH31***V*D1、CH31***V*00、CH31***V*S5/-NH/-LP採用以上相同PIN數包裝。 (包裝時,先放海綿墊→放產品→再放海綿墊)</p>																		

PACKING METHOD (包裝方式) :

1 PVC BAG (塑膠袋)
SIZE = L * W

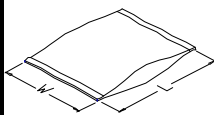

2 TUBE (塑膠管)
SIZE = L * W * H

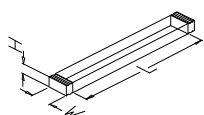

3 PVC TRAY (塑膠盒)
SIZE = L * W * H

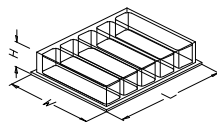

4 REEL (紙盤)
SIZE = D * W

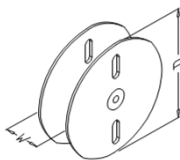

5 BOX (內紙盒)
SIZE = L * W * H

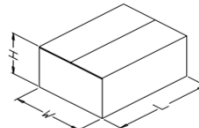

6 INSIDE CARTON (內箱)
SIZE = L * W * H

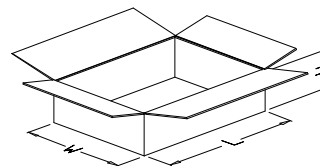

7 OUTSIDE CARTON (外箱)
SIZE = L * W * H

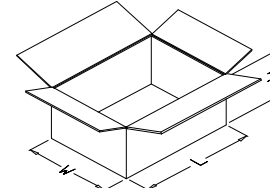

PACKING METHOD CODE (包裝方式代碼):

- A = 1 → 7
- B = 2 → 7
- C = (3+1) → 7
- D = 4 → 7
- E = 5 → 7
- F = 1 → 6 → 7
- G = 2 → 6 → 7
- H = 3 → 6 → 7

文件履歷表

文件編號	CI15H312				
文件名稱	PACKING STANDARD				
內容變更敘述					
版本	因內包裝增加海棉墊,變更包裝數量				發行日期
23	簽呈編號 : XQMS021400103				2014.11.11
核准	Jackal	審核	Mavis	製表	伍曉紅
版本					發行日期
核准		審核		製表	
版本					發行日期
核准		審核		製表	
版本					發行日期
核准		審核		製表	
版本					發行日期
核准		審核		製表	
版本					發行日期
核准		審核		製表	
版本					發行日期
核准		審核		製表	
版本					發行日期
核准		審核		製表	