

NOTE :

1. 10 sprocket hole pitch cumulative tolerance ± 0.20 .
2. Carrier camber is within 1 mm in 250mm.
3. Material : Clear,Transparent Polystyrene Alloy (UP-5200).
4. All dimensions meet EIA-481-C requirements.
5. Thickness : 0.40 ± 0.05 mm.
6. Packing length per 22" reel : 92.5 Meters.
7. Component load per 13" reel : 2400 pcs.

Circuits	Dimension					Packing (Reel/Caton)
	E	F	W1	W2	W3	
11~21	16.0(.630)	—	16.5(.650)	22.5(.886)	16.5(.650)	11
22~45	24.0(.945)	—	24.5(.965)	30.5(1.201)	24.5(.965)	9
46~61	32.0(1.260)	28.40(1.118)	32.5(1.280)	38.5(1.516)	32.5(1.280)	7

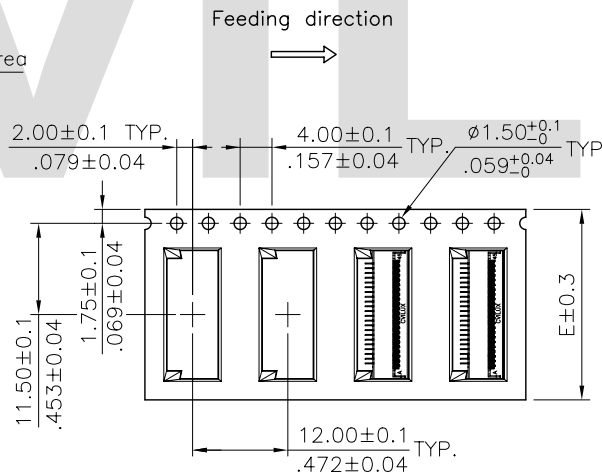
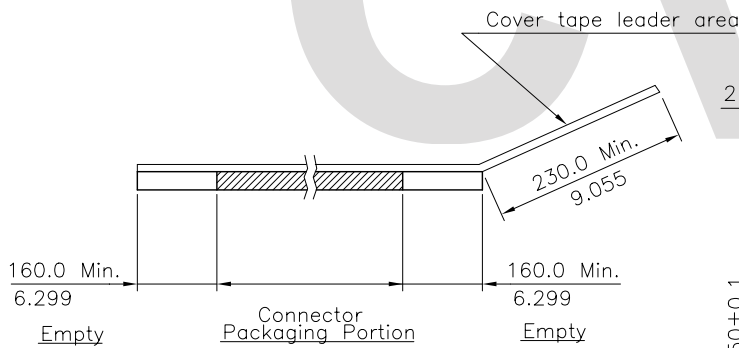

WIDTH : 16,24 mm Carrier

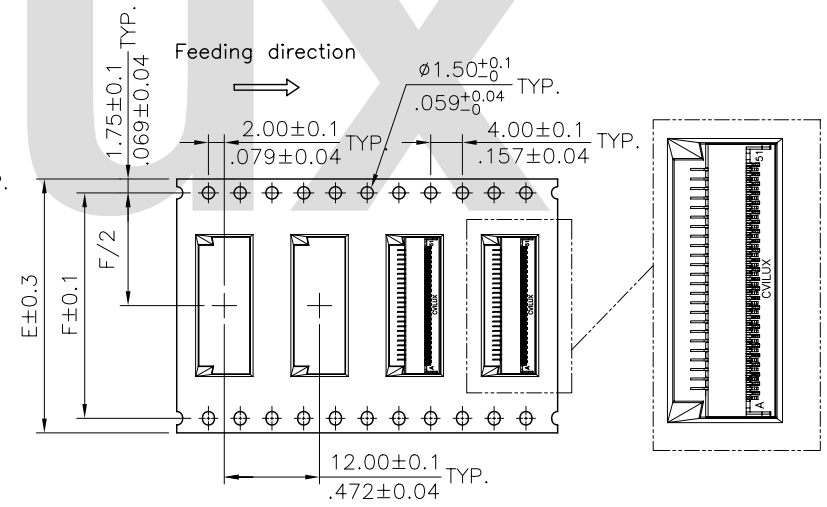

WIDTH : 32 mm Carrier

CIVILUX CORP
 2009.01.14
 ISSUED

REV	SYM	NAME	DATE	REVISIONS	APPROVED BY:	DATE	UNIT: mm / inch	TITLE: TAPE & REEL PACKAGING FOR CF30 SERIES	瀚荃股份有限公司 CviLux Corporation
4									
3					DRAWN BY: Karen	1/8-09'	TOLERANCE UNLESS OTHERWISE SPECIFIED	CF30 SERIES	SCALE
2	Karen	1/05-09'	ECN09003/ECR08099-0		ENGINEER: Eisley	1/9-09'	.X ± .X' ± 1'	MATERIAL:	
1	Sun	5/09-08'	ECN08210		CHECKED BY: David	1/7-09'	.XX ± .X ±	FINISH:	
					APPROVED BY: Alex	1/7-09'	.XXX ± .XX ±		