

Material :

- * Body : High Temperature plastic UL 94V-0
Color Nature
- * Slider : Glass filled Polyamide UL 94V-0
Color Black
- * Contact : Copper alloy
- * Fixed tab : Copper alloy

Ordering Code

CF30 ** 2 D 0 R B
① ② ③ ④ ⑤ ⑥ ⑦

- ① Series No.
- ② No. of Circuits
- ③ Plating code:
2 = Gold flash over 0.76μm(30μ") Nickel
- ④ Contact style: D = Downside contact
- ⑤ Color: 0 = Nature
- ⑥ Packing option: R = Tape & Reel
- ⑦ Other option: B = Lead Type

A = 0.30 * (No. of Contacts - 1)
 A1 = A - 0.6
 B = A + 2.6
 C = A + 0.63

* AVAILABLE IN 11 THROUGH 61 CIRCUITS

Lead Free Process
 RoHS Compliant

⑤	Karen	1/05-08'	ECN09003/ECR08099-0			DATE	UNIT: mm / inch	TITLE: 0.30mm(.012") ZIF FPC ONE-TOUCH CONNECTOR (H= 1.25mm)		瀚荃股份有限公司 CviLux Corporation	
④	Bill	6/13-08'	ECN08216		DRAWN BY:	Karen	1/8-09'	TOLERANCE UNLESS OTHERWISE SPECIFIED			MATERIAL:
③	Sun	5/09-08'	ECN08210		ENGINEER:	Eisley	1/9-09'	.X ± 0.15/.006 X' ± 1'			FINISH:
②	Bill	1/23-08	ECN08038		CHECKED BY:	David	1/7-09'	.XX ± 0.10/.004 .X' ±	DRAWING NO. CF3002SF	PART NO. CF30**2DORB	
SYM	NAME	DATE	REVISIONS		APPROVED BY:	Alex	1/7-09'	.XXX ± 0.05/.002 .XX' ±	SCALE 8 / 1	SHEET 1 OF 3	

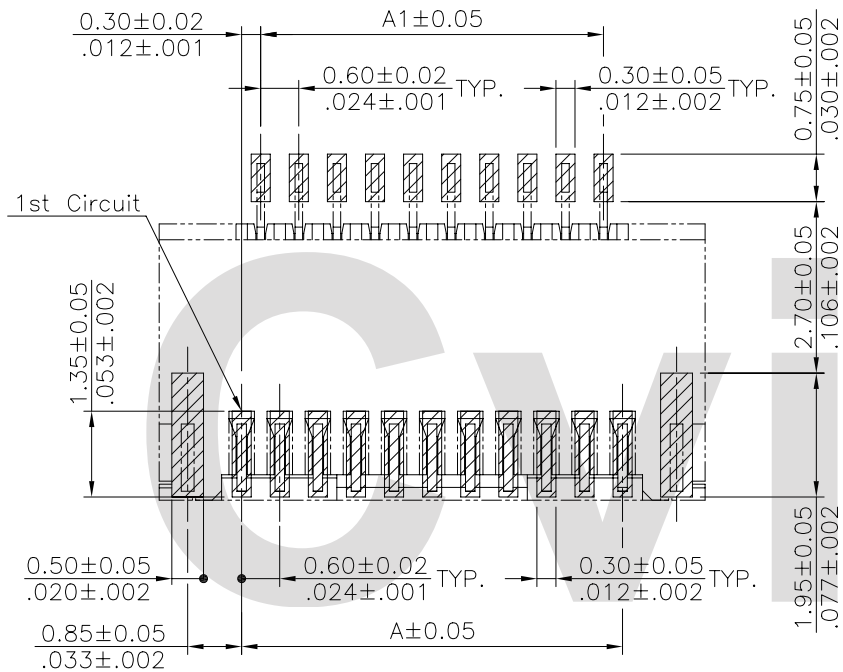

Recommended P.C. Board Layout

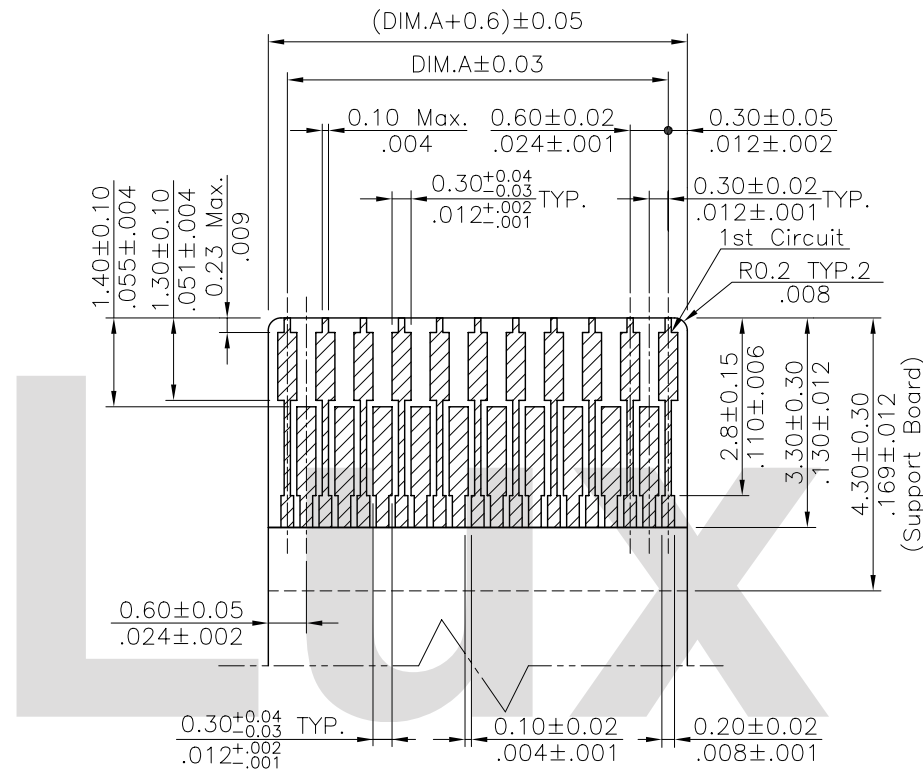



Recommended FPC Dimension

Thickness: 0.2±0.03mm

Lead Free Process

RoHS Compliant

5	Karen	1/05-08'	ECN09003/ECR08099-0	 2009.01.14 ISSUED		DATE	UNIT: mm / inch	TITLE: 0.30mm(.012") ZIF FPC ONE-TOUCH CONNECTOR (H= 1.25mm)	 瀚荃股份有限公司 CviLux Corporation		
4	Bill	6/13-08'	ECN08216		DRAWN BY: Karen	1/8-09'	TOLERANCE UNLESS OTHERWISE SPECIFIED			MATERIAL:	
3	Sun	5/09-08'	ECN08210		ENGINEER: Eisley	1/9-09'	.X ± 0.15/.006	.X' ± 1'			
2	Bill	1/23-08	ECN08038		CHECKED BY: David	1/7-09'	.XX ± 0.10/.004	.X' ±	FINISH:	DRAWING NO. CF3002SF	PART NO. CF30**2DORB
SYM	NAME	DATE	REVISIONS		APPROVED BY: Alex	1/7-09'	.XXX ± 0.05/.002	.XX' ±		SCALE 8 / 1	SHEET 2 OF 3

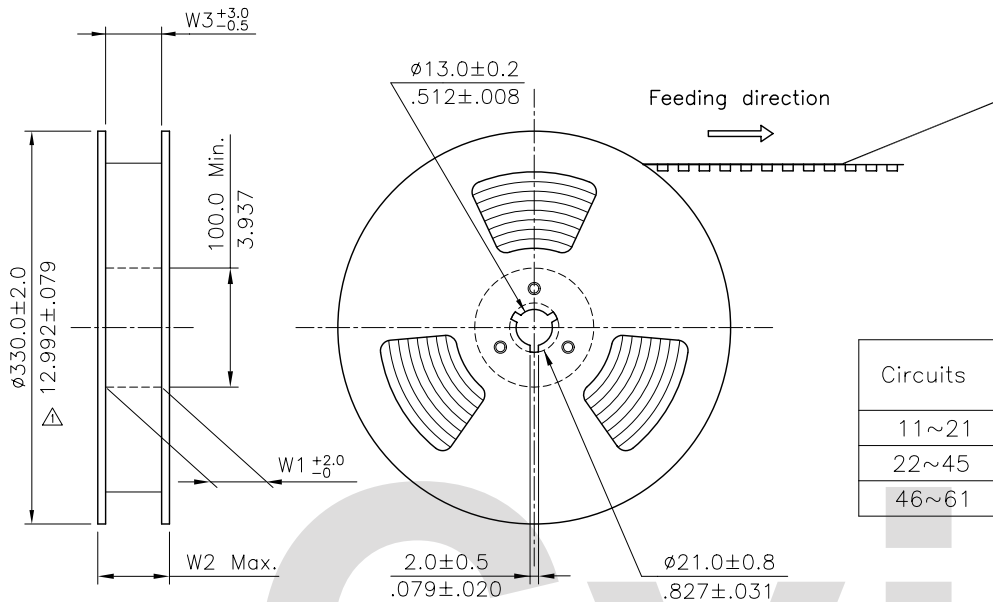

NOTE :

1. 10 sprocket hole pitch cumulative tolerance ± 0.20 .
2. Carrier camber is within 1 mm in 250mm.
3. Material : Clear,Transparent Polystyrene Alloy (UP-5200).
4. All dimensions meet EIA-481-C requirements.
5. Thickness : 0.40 ± 0.05 mm.
6. Packing length per 22" reel : 92.5 Meters.
7. Component load per 13" reel : 2400 pcs.

Circuits	Dimension					Packing (Reel/Caton)
	E	F	W1	W2	W3	
11~21	16.0(.630)	—	16.5(.650)	22.5(.886)	16.5(.650)	11
22~45	24.0(.945)	—	24.5(.965)	30.5(1.201)	24.5(.965)	9
46~61	32.0(1.260)	28.40(1.118)	32.5(1.280)	38.5(1.516)	32.5(1.280)	7

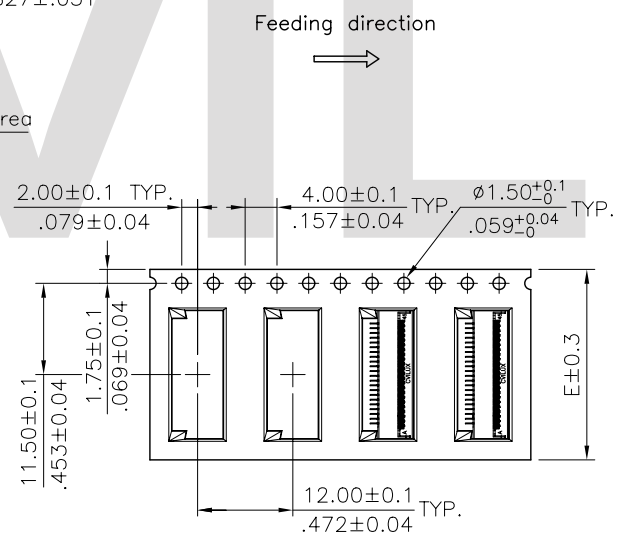
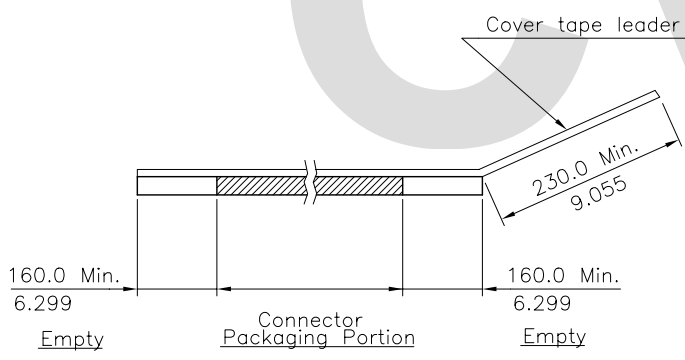

WIDTH : 16,24 mm Carrier

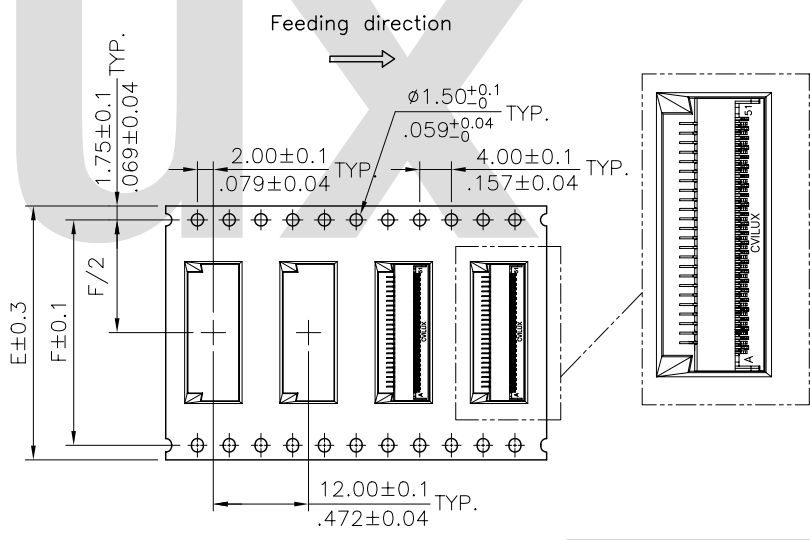

WIDTH : 32 mm Carrier

RoHS Compliant

5	Karen	1/05-08'	ECN09003/ECR08099-0		DATE	UNIT: mm / inch	TITLE: TAPE & REEL PACKAGING FOR CF30 SERIES	瀚荃股份有限公司 CviLux Corporation		
4	Bill	6/13-08'	ECN08216		DRAWN BY: Karen	1/8-09'			TOLERANCE UNLESS OTHERWISE SPECIFIED	MATERIAL:
3	Sun	5/09-08'	ECN08210		ENGINEER: Eisley	1/9-09'			.X ± .X' ± 1'	
2	Bill	1/23-08	ECN08038		CHECKED BY: David	1/7-09'	.XX ± .X' ±	FINISH:		
SYM	NAME	DATE	REVISIONS		APPROVED BY: Alex	1/7-09'	.XXX ± .XX' ±	SCALE	DRAWING NO. CF3002SF	
								PART NO. CF30**2DORB		
								SHEET 3 OF 3		