

Dim.A = 1.00 x No. of Spaces
 Dim.B = DIM.A + 3.5
 Dim.C = DIM.A + 2.0
 △ Available in 4 ~ 10 Circuits

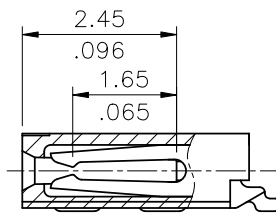

SEC.:Y-Y

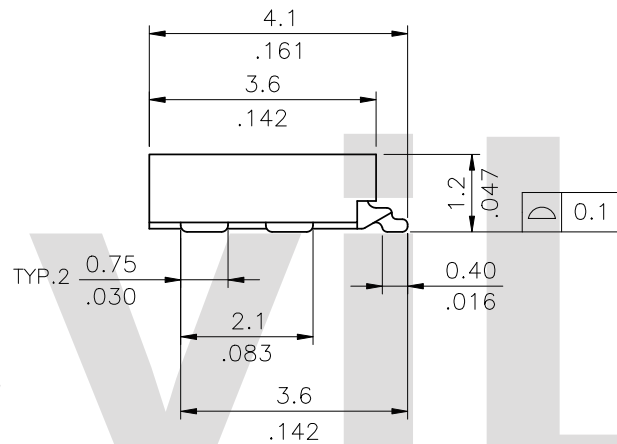
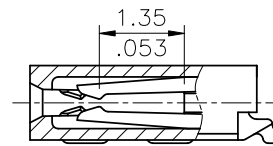

SEC.: X-X

Material :

- * Body : High temperature plastic UL 94V-0, Color Nature
- * Contact : Copper alloy
- * Fixed tab : Copper alloy With Matte Tin plated

Ordering Code

CF27 ** * H 0 * 0 -10 -NH
 ① ② ③ ④ ⑤ ⑥ ⑦ ⑧ ⑨

- ① Series No.
- ② No. of Circuits
- ③ Plating code:
 1= 3.05μm(120μ") Min. Matte Tin over 0.76μm(30μ") Nickel
 2= Gold flash plated over 50u"min. Nickel
- ④ Contact style: H= Side Entry
- ⑤ Color: 0= Nature
- ⑥ Packing option: R= Tape & Reel
 T= Tube Packing
- ⑦ Option: 0= Standard
- ⑧ Pitch: 10= 1.0 mm
- ⑨ Process:
 -NH= For Lead Free soldering process and Halogen-Free

Halogen-Free

Lead Free Process

RoHS Compliant

④					DATE	UNIT: mm / inch	TITLE: 1.00mm(.039") LIF FFC/FPC CONNECTOR	瀚荃股份有限公司 CviLux Corporation
③					DRAWN BY: Sun	8/24-11'	TOLERANCE UNLESS OTHERWISE SPECIFIED	
②					ENGINEER: Eisley	8/24-11'	MATERIAL:	DRAWING NO. CF2708SA PART NO. CF27***H0*0-10-NH
①	Una	4/1-11'	ECN11008-N		CHECKED BY: David	8/24-11'	FINISH:	
SYM	NAME	DATE	REVISIONS		APPROVED BY: David	8/24-11'	.X ± 0.15/006 .XX ± 0.10/004 .XXX ± 0.05/002	SCALE 8 / 1 SHEET 1 OF 3



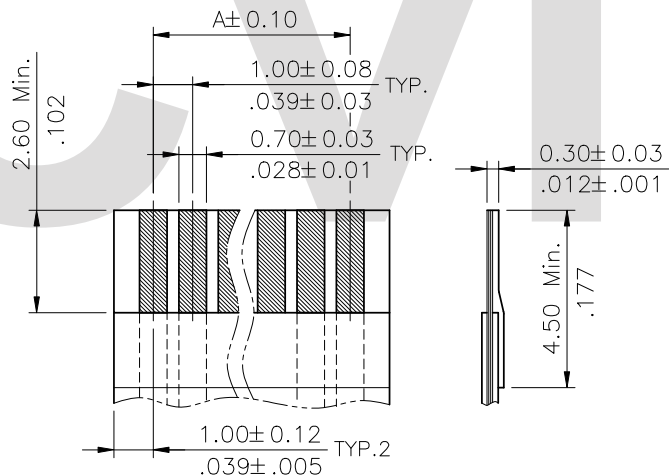
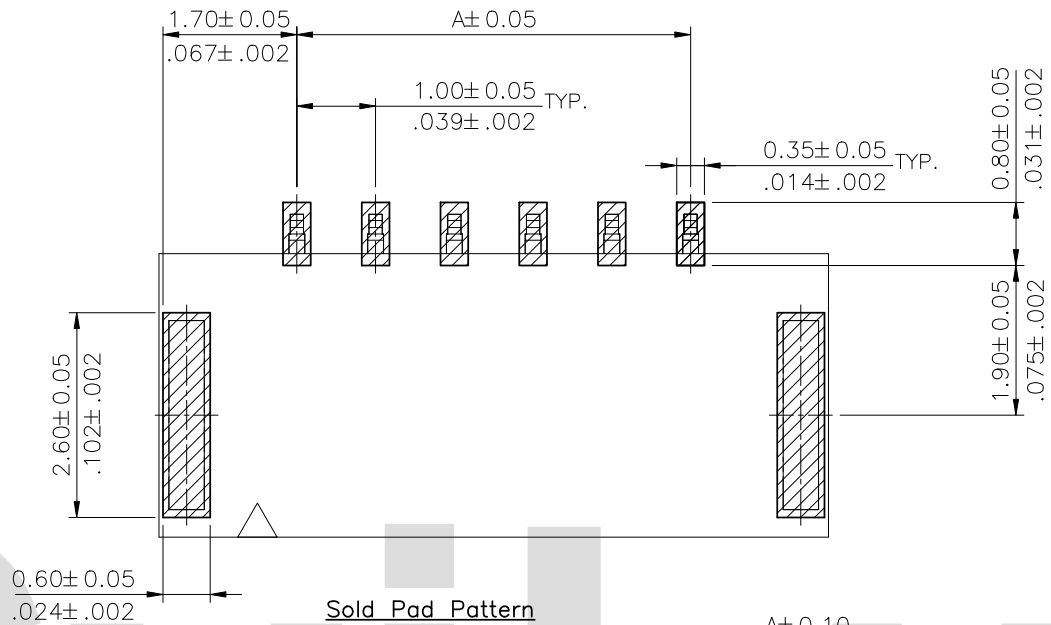
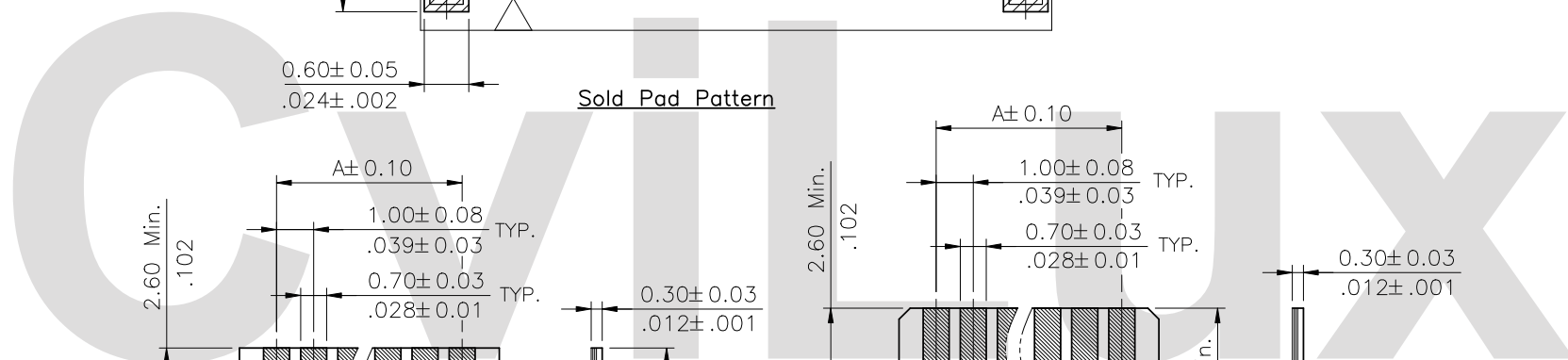

Accommodated FFC

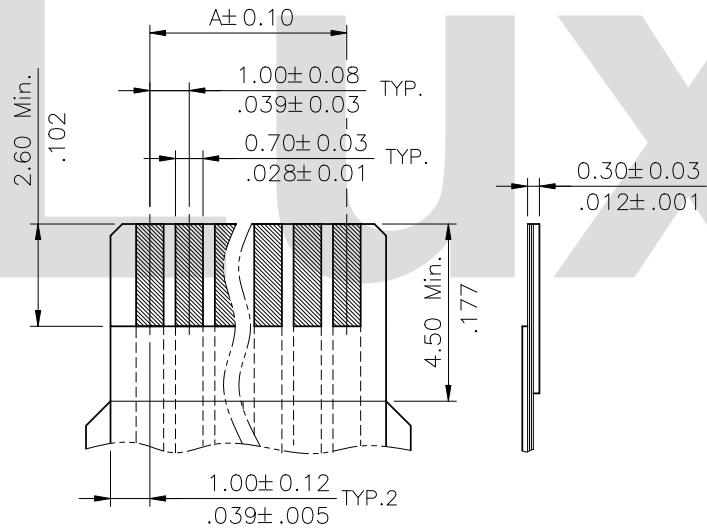

Accommodated FPC

Halogen-Free
Lead Free Process
RoHS Compliant

4						DATE	UNIT: mm / inch	TITLE: 1.00mm(.039") LIF FFC/FPC CONNECTOR	 瀚荃股份有限公司 CviLux Corporation
3						DRAWN BY: Sun	TOLERANCE UNLESS OTHERWISE SPECIFIED	MATERIAL:	
2						ENGINEER: Eisley	.X ± 0.15/.006 X: ± 1'	FINISH:	DRAWING NO. CF2708S2
1	Una	4/1-11'	ECN11008-N			CHECKED BY: David	.XX ± 0.10/.004 X: ±		PART NO. CF27***H0*0-10-NH
SYM	NAME	DATE	REVISIONS			APPROVED BY: Daivd	.XXX ± 0.05/.002 XX: ±		SCALE 10 / 1
									SHEET 2 OF 3

CIVILUX CORP
 2011.08.24
 ISSUED

