

DETAIL "A-A"

Material :

- * Body : NYLON 46 With 40% GF.
UL 94V-0, Color Nature
- * Contact : Phosphor Bronze

A = 0.50 x No. of Spaces
 B = A + 2.2
 C = A + 1.1

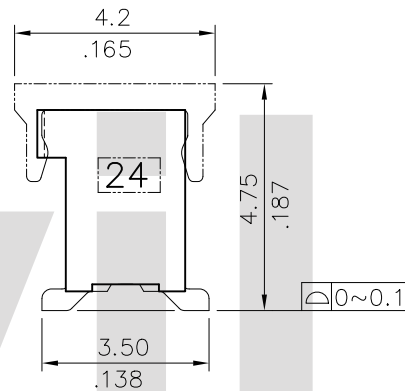
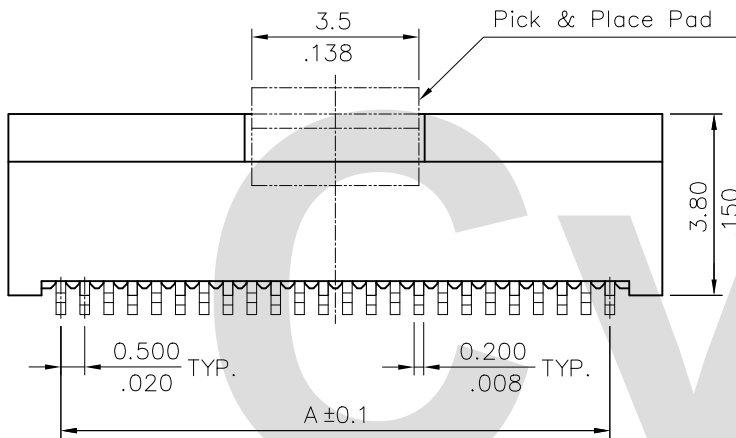

Ordering Code

CF24 ** 1 V 0 * *
 ① ② ③ ④ ⑤ ⑥ ⑦

- ① Series No.
- ② Contacts: 04 To 50
- ③ Plating code: 1= 3.05μm(120μ") Min. Tin
over 0.76μm(30μ") Nickel
2= Gold flash plated
over 1.27μm(50μ") Nickel
- ④ Contact style: V= Vertical Type
- ⑤ Color: 0= Nature
- ⑥ Packing Type: R= Tape & Reel
T= Tube Packing
- ⑦ Other options: 0= With PAD (Standard)
N= Without PAD

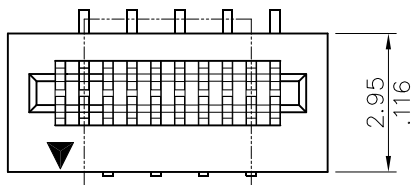

4~9PIN

Tin-Lead Process

RoHS Compliant

④					DATE	UNIT: mm / inch	TITLE: 0.50mm(.031") LIF FFC/FPC VERTICAL TYPE SURFACE MOUNT CONNECTOR	
③	Enya	10/24-13'	ECNT113082/ECRB113023	DRAWN BY:	Enya	10/24-13'		TOLERANCE UNLESS OTHERWISE SPECIFIED
②	Sandy	10/13-09'	ECN09493	ENGINEER:	Sun	10/25-13'		.X ± 0.15/.006 X' ± 1'
①	Sun	5/02-07'	ECR07020-1/ECN07168	CHECKED BY:	Eisley	10/29-13'		.XX ± 0.10/.004 .X' ±
SYM	NAME	DATE	REVISIONS	APPROVED BY:	Eisley	10/29-13'	.XXX ± 0.05/.002 .XX' ±	

CVILUX CORP
 2013.11.07
 ISSUED



瀚荃股份有限公司
CviLux Corporation

DRAWING NO.	CF2401SD	PART NO.	CF24***V0**
SCALE	6 / 1	SHEET	1 OF 3

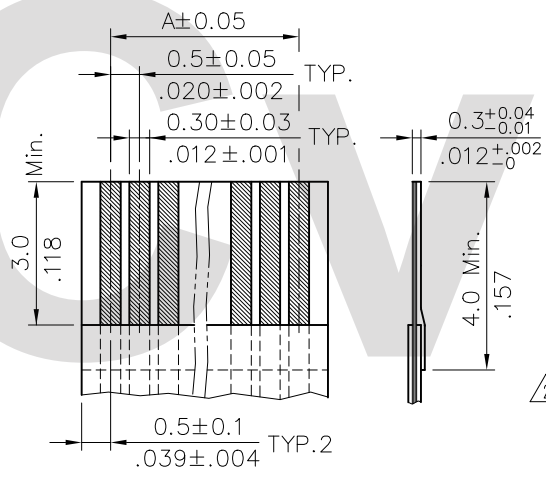

Accommodated FFC/FPC

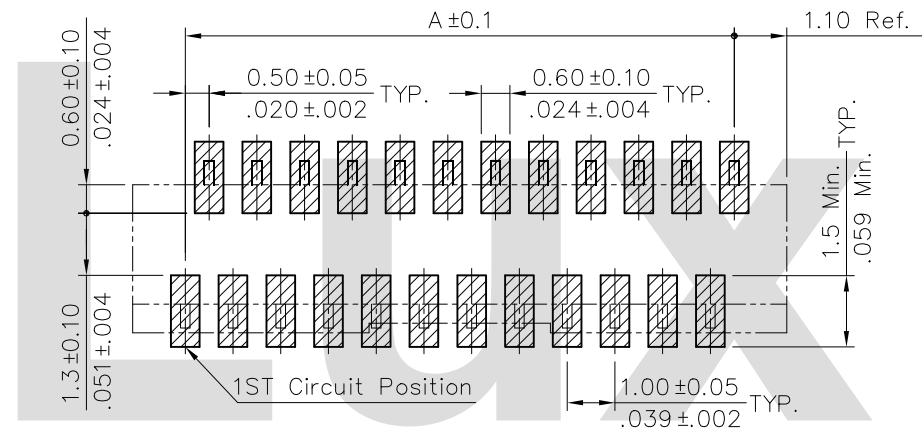

Sold Pad Pattern

Tin-Lead Process RoHS Compliant

4						DATE	UNIT: mm / inch	TITLE: 0.50mm(.031") LIF FFC/FPC VERTICAL TYPE SURFACE MOUNT CONNECTOR
3	Enya	10/24-13'	ECNT113082/ECRB113023	DRAWN BY:	Enya	10/24-13'	TOLERANCE UNLESS OTHERWISE SPECIFIED	
2	Sandy	10/13-09'	ECN09493	ENGINEER:	Sun	10/25-13'	.X ± 0.15/.006 .X' ± 1"	
1	Sun	5/02-07'	ECR07020-1/ECN07168	CHECKED BY:	Eisley	10/29-13'	.XX ± 0.10/.004 .X' ±	
SYM	NAME	DATE	REVISIONS	APPROVED BY:	Eisley	10/29-13'	.XXX ± 0.05/.002 .XX' ±	MATERIAL:
								CUSTOMER:

CVILUX CORP
2013.11.07
ISSUED

瀚荃股份有限公司
CviLux Corporation

DRAWING NO.	CF2401SD	PART NO.	CF24***V0**
SCALE	6 / 1	SHEET	2 OF 3

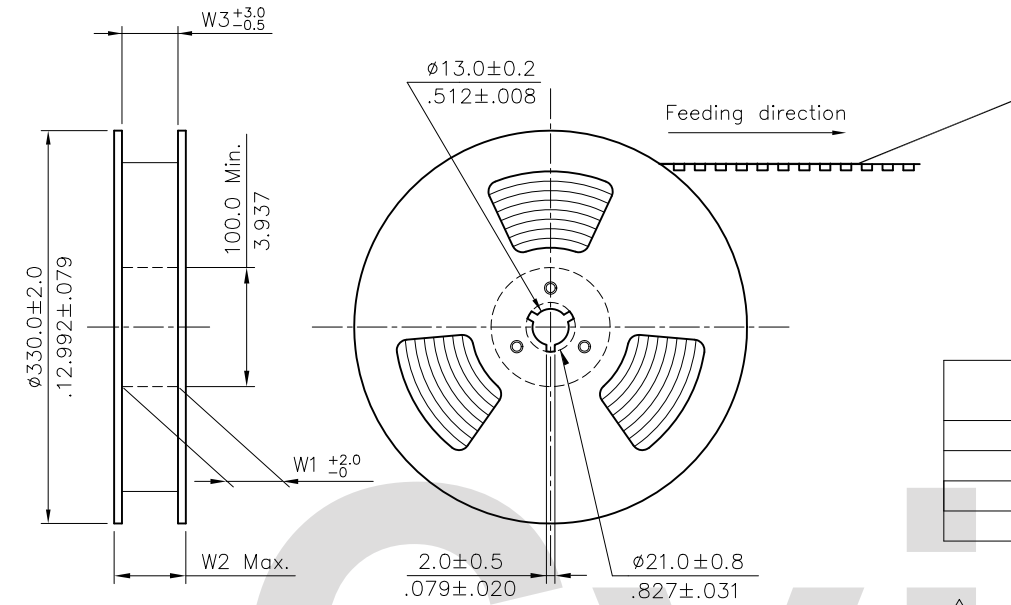

NOTES:

1. 10 sprocket hole pitch cumulative tolerance ± 0.20 .
2. Carrier camber is within 1 mm in 250 mm.
3. Material : Clear,Transparent Polystyrene Alloy (UP-6000).
4. All dimensions meet EIA-481-B requirements.
5. Thickness : 0.40 ± 0.05 mm.
6. Packing length per 22" reel : 98.5 Meters.
7. Component load per 13" reel : 1000 pcs.

Circuits	Dimension					Packing (Reel/Caton)
	E	F	W1	W2	W3	
4-14	16.0(.630)	—	16.5(.650)	22.5(.886)	16.5(.650)	11
15-30	24.0(.945)	—	24.5(.965)	30.5(1.200)	24.5(.965)	9
31-38	32.0(1.260)	28.40(1.118)	32.5(1.280)	38.5(1.516)	32.5(1.280)	7
39-50	44.0(1.732)	40.40(1.596)	44.5(1.752)	50.5(1.988)	44.5(1.752)	5

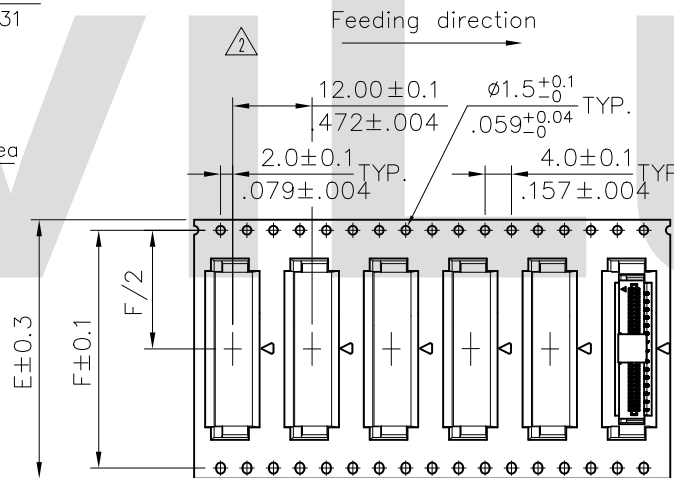
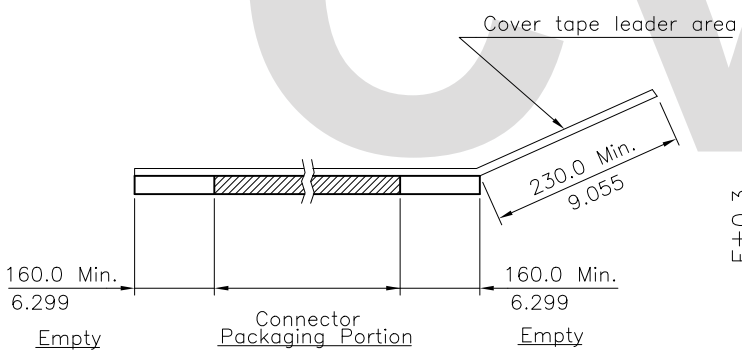

WIDTH : 32, 44 mm Carrier

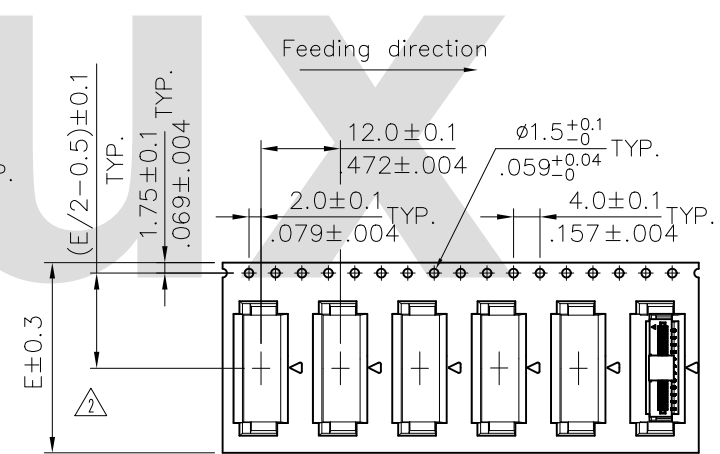

WIDTH : 16, 24 mm Carrier

RoHS Compliant

4						DATE	UNIT: mm / inch	TITLE: 0.50mm(.031") LIF FFC/FPC VERTICAL TYPE SURFACE MOUNT CONNECTOR	 瀚荃股份有限公司 CviLux Corporation
3	Enya	10/24-13'	ECNT113082/ECRB113023	DRAWN BY: Enya	10/24-13'	TOLERANCE UNLESS OTHERWISE SPECIFIED	MATERIAL:	DRAWING NO. CF2401SD	
2	Sandy	10/13-09	ECN09493	ENGINEER: Sun	10/25-13'	.X ±	X' ± 1'	PART NO. CF24***V0**	
1	Sun	5/02-07'	ECR07020-1/ECN07168	CHECKED BY: Eisley	10/29-13'	.XX ±	.X' ±	SCALE	
SYM	NAME	DATE	REVISIONS	APPROVED BY: Eisley	10/29-13'	.XXX ±	.XX' ±	SHEET 3 OF 3	

CVILUX CORP
 2013.11.07
 ISSUED