

Ordering Code

CF20 ** 1 D 0 ** -10 -NH
 ① ② ③ ④ ⑤ ⑥ ⑦ ⑧

- ① Series No.
- ② No. of Circuits
- ③ Plating code:
1 = 3.05μm(120μ") Min. Matte Tin over 0.76μm(30μ") Nickel
- ④ Contact style: D= Downside contact
- ⑤ Color: 0= Nature
- ⑥ Other option: R0= Tape & Reel
T0= Tube Packing
- ⑦ Pitch: 10= 1.00 mm
- ⑧ Other option:
NH= For Lead Free IR Processes and Halogen-Free

Material :

- * Body : High temperature plastic UL 94V-0
Color Nature(Ivory)
- * Slider : High temperature plastic UL 94V-0
Color Black
- * Contact : Copper alloy with Matte Tin plated
- * Fixed tab : Copper alloy with Matte Tin plated

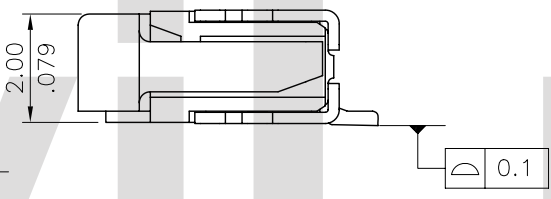
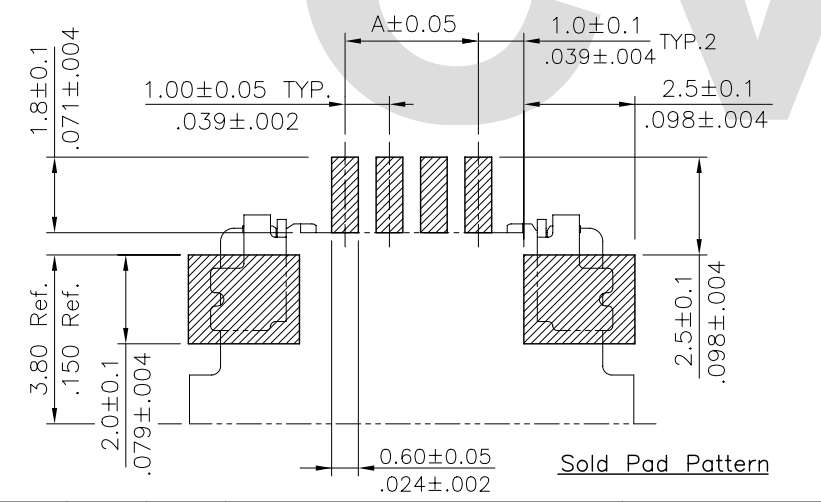
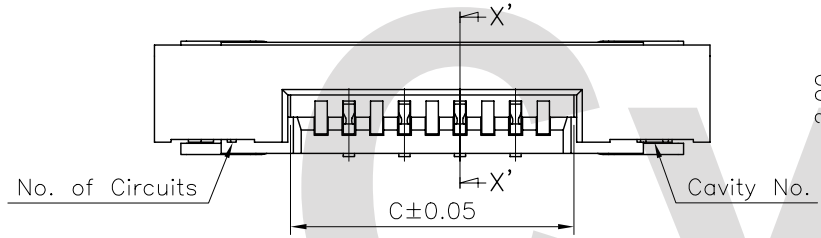
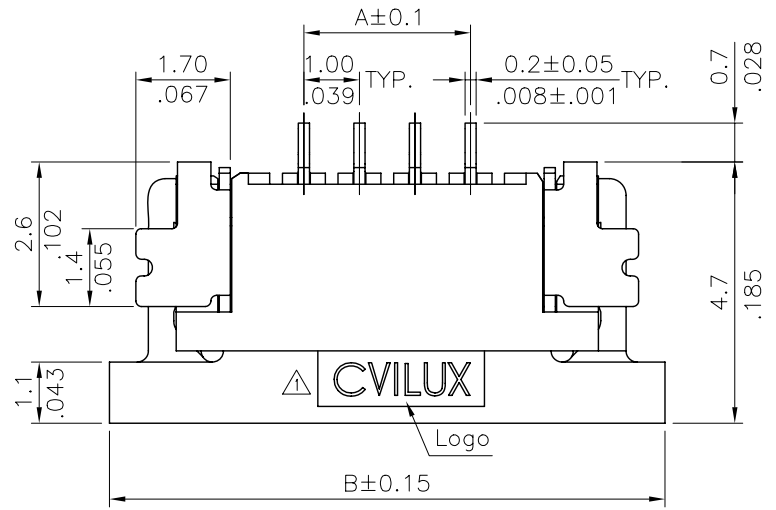

A = 1.0 * No. of Spaces
 B = A + 7.0
 C = A + 2.1

* Available in 2 through 27 circuits

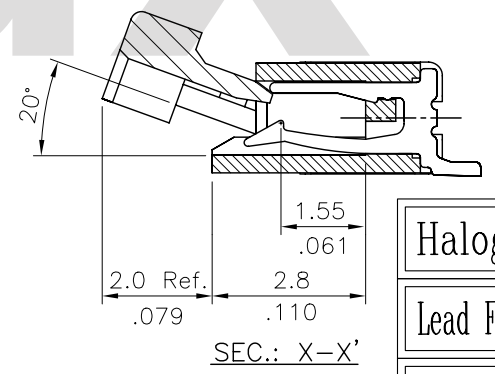
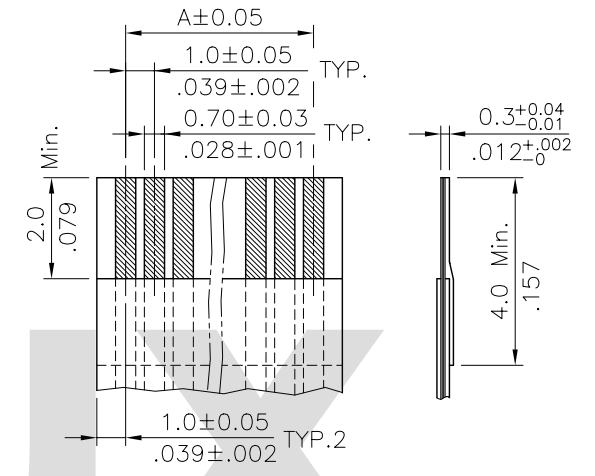
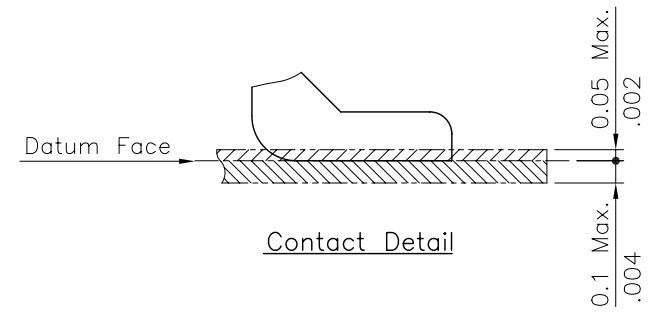

Halogen-Free
 Lead Free Process
 RoHS Compliant

④					DATE	UNIT: mm / inch	TITLE: 0.50mm(.031") ZIF FFC/FPC DOWNSIDE CONTACT SURFACE MOUNT CONNECTOR	 瀚荃股份有限公司 CviLux Corporation
③					DRAWN BY: Karen	9/29-09'	TOLERANCE UNLESS OTHERWISE SPECIFIED	
②					ENGINEER: Eisley	10/5-09'	.X ± 0.15/.006 X' ± 1'	MATERIAL:
①	Karen	8/25-09'	ECN09413/ECR09116-0		CHECKED BY: David	10/5-09'	.XX ± 0.10/.004 X' ±	FINISH:
SYM	NAME	DATE	REVISIONS		APPROVED BY: Alex	10/5-09'	.XXX ± 0.05/.002 X' ±	DRAWING NO. CF2006AB
								PART NO. CF20**1D0**-10-NH
								SCALE 7 / 1
								SHEET 1 OF 2

CVILUX CORP
 2009.10.27
 ISSUED

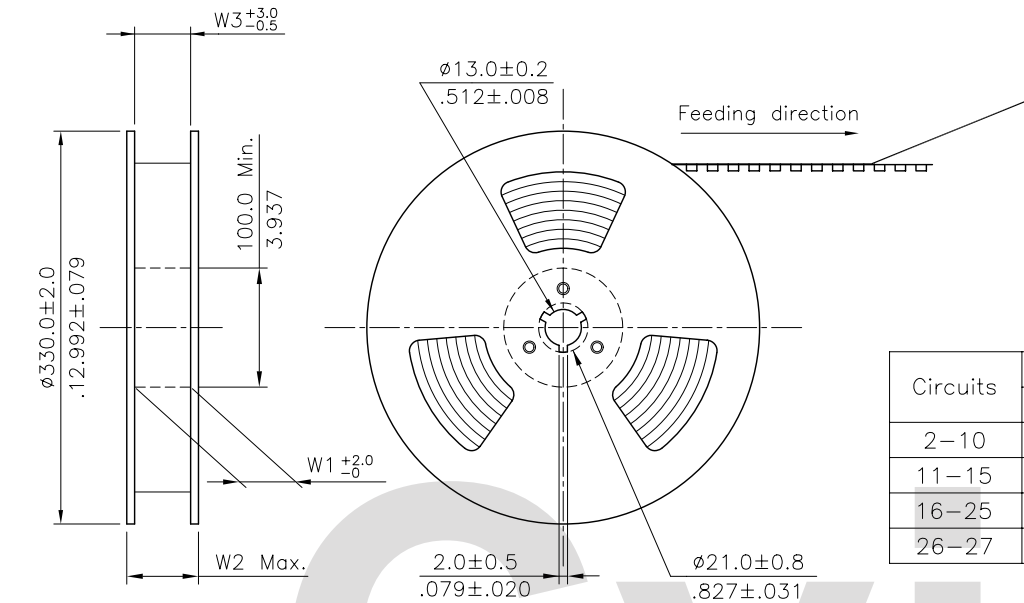

NOTE :

- * Reel Material : HIPS
- * Carrier Material : Clear, Conductive Polystyrene Alloy
- * Cover Tape Material : Polyester
- * Cover Tape Peel Strength : 0.1N – 1.3N
- * Carrier camber is within 1mm in 100mm
- * All dimensions meet EIA-481-2 & EIA-481-3 requirements.
- * Quantity : 2000 PCS/Reel

Circuits	Dimension					Packing (Reel/Caton)
	E	F	W1	W2	W3	
2-10	24.0(.945)	-	24.5(.965)	30.5(1.200)	24.5(.965)	9
11-15	32.0(1.260)	28.40(1.118)	32.5(1.280)	38.5(1.516)	32.5(1.280)	7
16-25	44.0(1.732)	40.40(1.596)	44.5(1.752)	50.5(1.988)	44.5(1.752)	5
26-27	56.0(2.205)	52.40(2.063)	56.5(2.224)	62.5(2.461)	56.5(2.224)	4

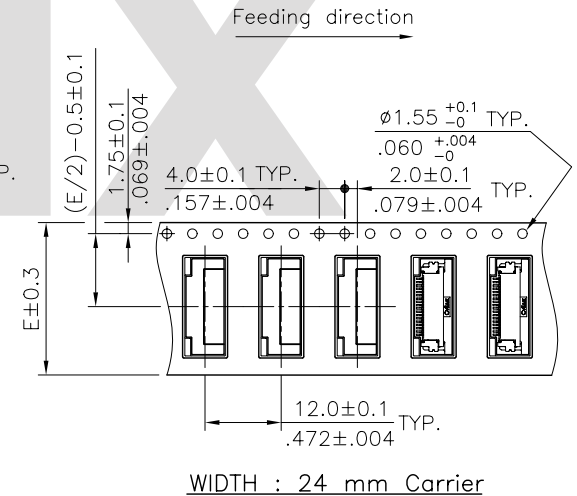
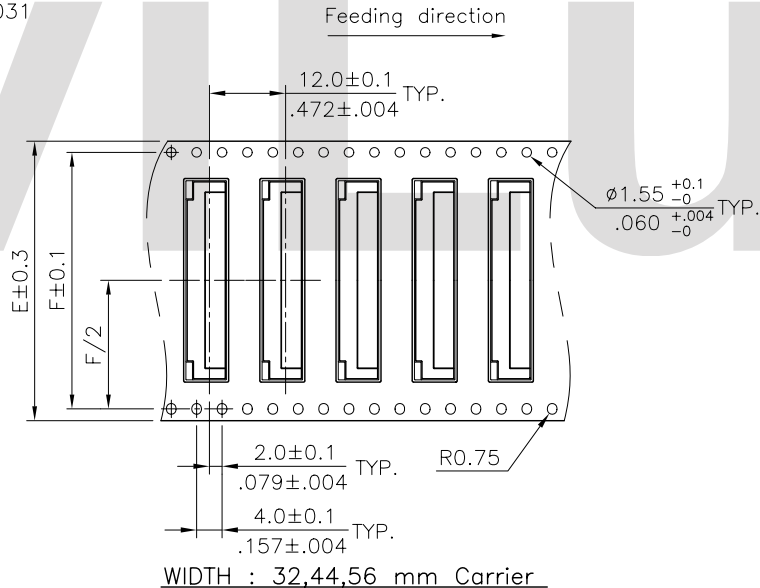
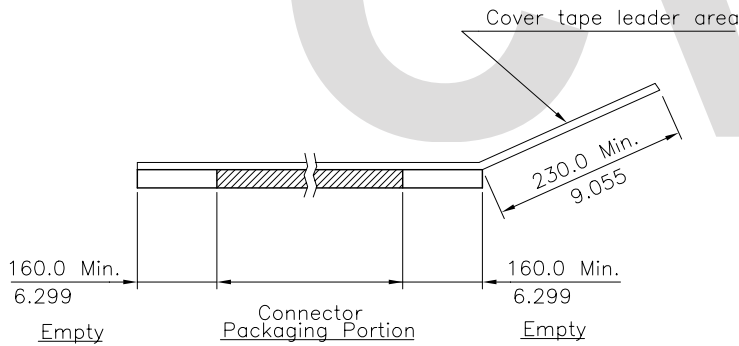

RoHS Compliant

	 2009.10.27 ISSUED	DRAWN BY: Karen ENGINEER: Eisley CHECKED BY: David APPROVED BY: Alex	DATE 9/29-09' 10/5-09' 10/5-09' 10/5-09'	UNIT: mm / inch TOLERANCE UNLESS OTHERWISE SPECIFIED .X ± .X' ± 1' .XX ± .X' ± .XXX ± .XX' ±	TITLE: 0.50mm(.031") ZIF FFC/FPC DOWNSIDE CONTACT SURFACE MOUNT CONNECTOR MATERIAL: FINISH:	瀚荃股份有限公司 CviLux Corporation			
						SCALE		SHEET 2 OF 2	