

NOTE :

- * Reel Material : HIPS
- * Carrier Material : Clear, Conductive Polystyrene Alloy
- * Cover Tape Material : Polyester
- * Cover Tape Peel Strength : 0.1N – 1.3N
- * Carrier camber is within 1mm in 250mm
- * All dimensions meet EIA-481-B requirements.
- * Quantity : 800 PCS/Reel

Circuits	Dimension					Packing (Reel/Caton)
	E	F	W1	W2	W3	
3~11	24.0(.945)	---	24.5(.965)	30.5(1.201)	24.5(.965)	9
12~16	32.0(1.260)	28.40(1.118)	32.5(1.280)	38.5(1.516)	32.5(1.280)	7
17~27	44.0(1.732)	40.40(1.591)	44.5(1.752)	50.5(1.988)	44.5(1.752)	5
28~32	56.0(2.205)	52.40(2.063)	56.5(2.224)	62.5(2.461)	56.5(2.224)	3

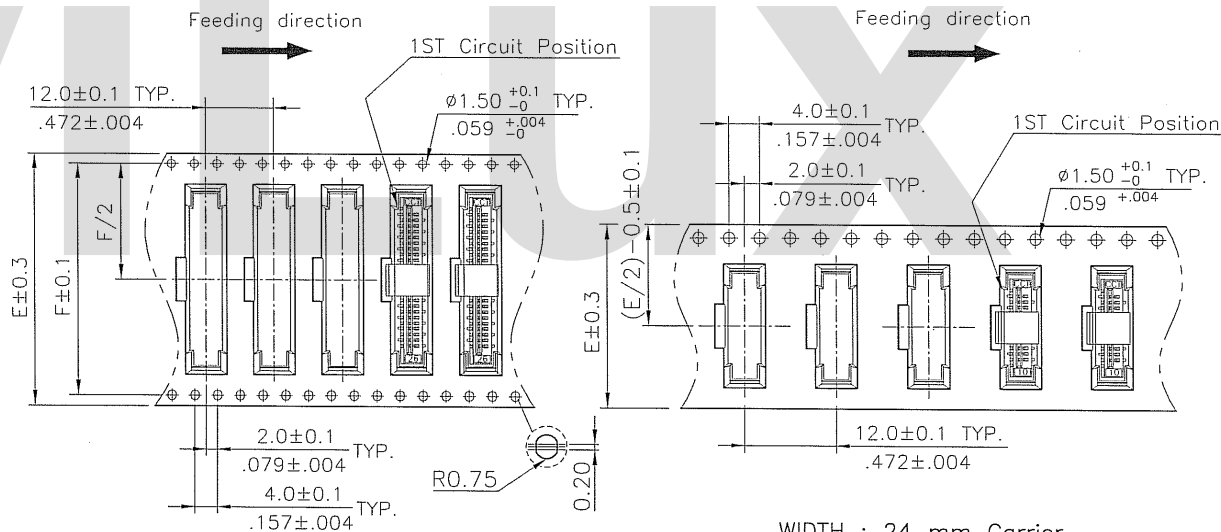
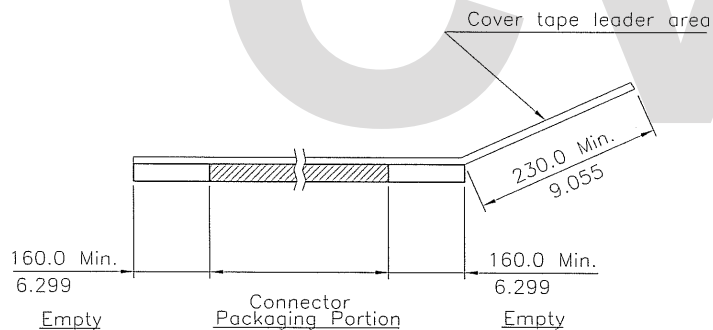

WIDTH : 32, 44 & 56 mm Carrier

REV	SYM	NAME	DATE	REVISIONS	APPROVED BY:	DATE	UNIT: mm / inch	TITLE: TAPE & REEL PACKAGING FOR CF16 SERIES SMT TYPE
4	SUN	4/27/05'	ECR05029	ECN05140				
3	SUN	12/20/04	ECR04083	ECN04507	DRAWN BY: Eager	2/27-06'	TOLERANCE UNLESS OTHERWISE SPECIFIED	MATERIAL:
2	Sandy	12/10/04'	ECN04488		ENGINEER: Zisley	6/7-06'		
5	Eager	6/8/06'	ECN06171		CHECKED BY: David	6/27-06'	.XX ±	.X' ±
					APPROVED BY: A/S	6/27-06'	.XXX ±	.XX' ±

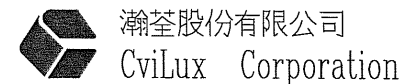

DRAWING NO.	CF1612SG	PART NO.	
SCALE		SHEET	1 OF 1