

NOTE :

- \* Reel Material : HIPS
- \* Carrier Material : Clear, Conductive Polystyrene Alloy
- \* Cover Tape Material : Polyester
- \* Cover Tape Peel Strength : 0.1N – 1.3N
- \* Carrier camber is within 1mm in 100mm
- \* All dimensions meet EIA-481-2 & EIA-481-3 requirements.
- \* Quantity : 1000 PCS/Reel

Circuits	Dimension					Packing (Reel/Caton)
	E	F	W1	W2	W3	
10~20	16.0(.630)	-	16.5(.650)	22.5(.886)	16.5(.650)	11
22~46	24.0(.945)	-	24.5(.965)	30.5(1.200)	24.5(.965)	9
48~60	32.0(1.260)	28.40(1.118)	32.5(1.280)	38.5(1.516)	32.5(1.280)	7

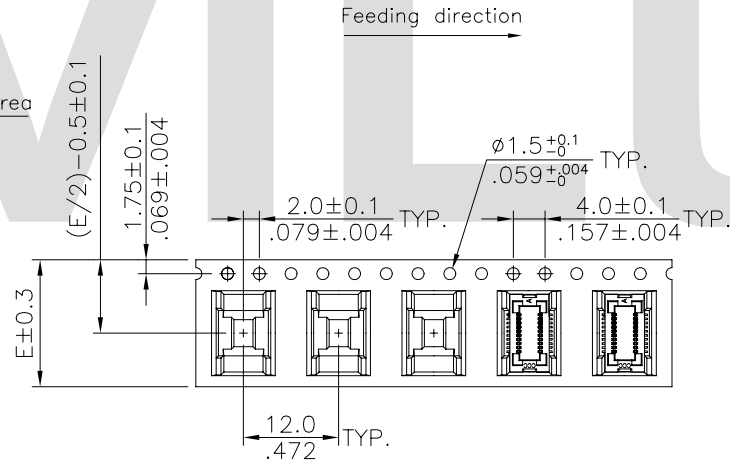
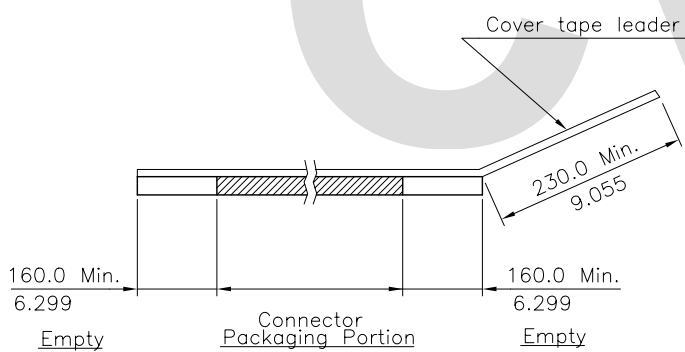

WIDTH : 16.24 mm Carrier

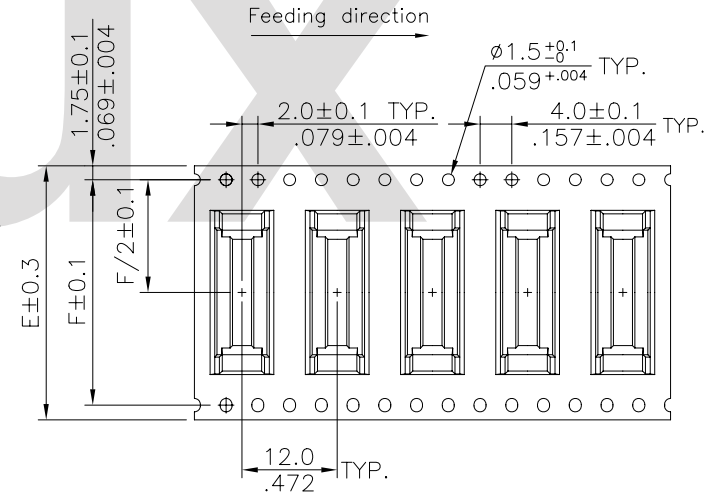

WIDTH : 32 mm Carrier

4						DATE	UNIT: mm / inch	TITLE: TAPE & REEL PACKAGING FOR CBRB RECEPTACLE TYPE	 瀚荃股份有限公司 CviLux Corporation
3						DRAWN BY: Jason	TOLERANCE UNLESS OTHERWISE SPECIFIED	MATERIAL:	
2						ENGINEER: Eisley	.X ±	X' ± 1'	DRAWING NO. CBRB03SA
1	JASON	03/02-05	ECN05080			CHECKED BY: David	.XX ±	.X' ±	PART NO.
SYM	NAME	DATE	REVISIONS			APPROVED BY: Alex	.XXX ±	.XX' ±	SCALE
									SHEET 1 OF 1

CVILUX.CORP  
 2005.03.15  
 ISSUED