

Material:
 * Insulation: High Temperature Plastic UL 94V-0
 * Contact: Phosphor Bronze

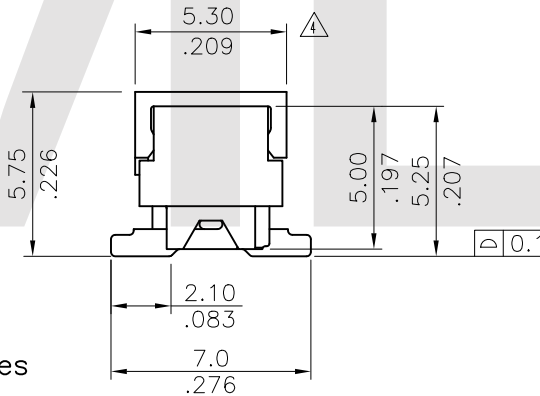
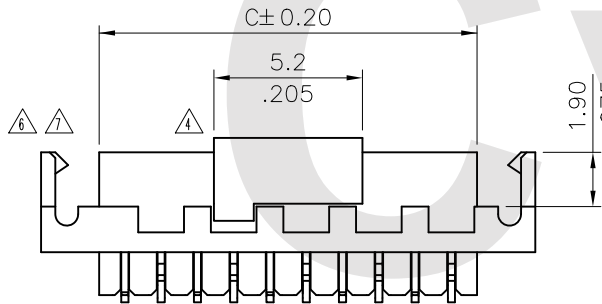
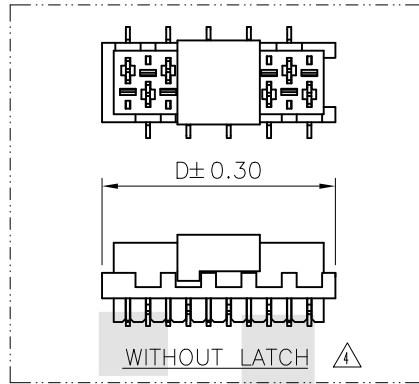
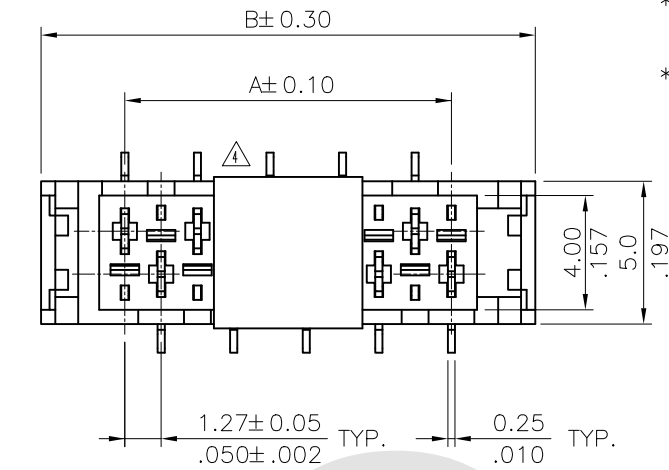

DIM.A= 1.27 x No. of Spaces
 DIM.B= DIM.A + 5.87
 DIM.C= DIM.A + 1.80
 DIM.D= DIM.A + 3.27
 *Available in 4 ~ 26 Circuits

Ordering Code:

CA32 ** M 1 3 0 0
 ① ② ③ ④ ⑤ ⑥ ⑦

- ① Series No.:
- ② No. of Circuits: 04 to 26
- ③ Contacts Type:
M= SMT Type
- ④ Plating option:
1= Tin over Nickel plated
(Matte Tin plated)
- ⑤ Color: 3= Red
- ⑥ Pad Option: 0= With Pad (Reel Packing)
P= Without Pad (Reel Packing)
D= With Pad (Tube Packing)
T= Without Pad (Tube Packing)
- ⑦ Latch Option: 0= Without Latch
L= With Latch

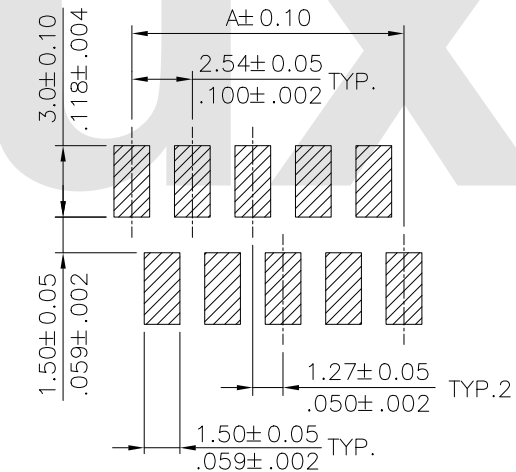

Recommended P.C. Board Layout

Lead Free Process

RoHS Compliant

CVILUX CORP
2016.12.01
ISSUED

⑦	Sun	11/21-16'	ECRB116078/ECNT116286	DATE	UNIT: mm / inch	TITLE: 1.27mm Pitch Female Top entry SMT Type Connector	 瀚荃股份有限公司 CviLux Corporation
⑥	Sun	3/11-16'	ECRT116009/ECNT116035	DRAWN BY: Sun	11/21-16'	TOLERANCE UNLESS OTHERWISE SPECIFIED	
⑤	Sun	5/04-12'	ECN12080-0/ECR12003-1	ENGINEER: Sun	11/21-16'	.X ± 0.3/.012 X' ± 1'	
④	Sun	7/28-10'	ECN10269/ECR10097-0	CHECKED BY: Easley	11/25-16'	.XX ± 0.2/.008 X' ±	
SYM	NAME	DATE	REVISIONS	APPROVED BY: Easley	11/25-16'	.XXX ± 0.1/.004 XX' ±	DRAWING NO. CA3203SH PART NO. CA32**M13** SCALE 4 / 1 SHEET 1 OF 2

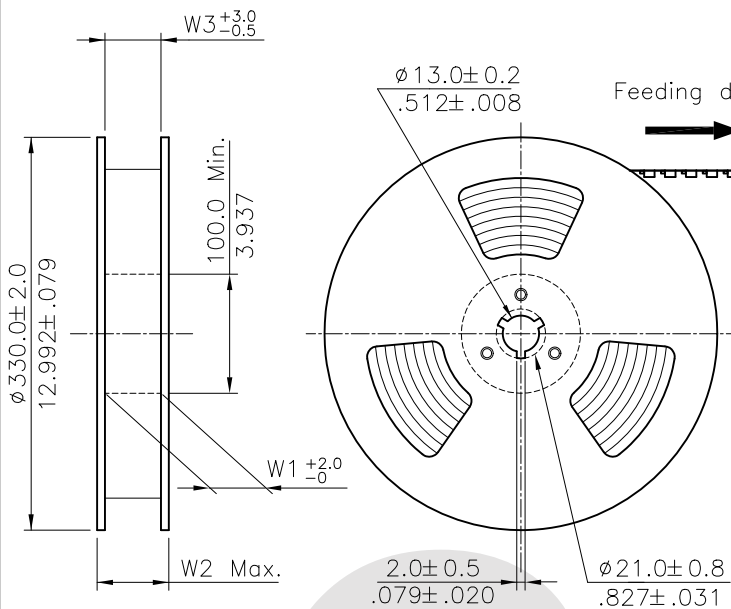

NOTES:

1. 10 sprocket hole pitch cumulative tolerance ± 0.20 mm.
2. Carrier camber not to exceed 1 mm in 100 mm.
3. Material :Transparent Anti-static Polysyrene.
4. All dimensions meet EIA-481-3 requirements.
5. Thickness : 0.40 ± 0.05 mm.
6. Packing length per 22" Reel : 30.6 Meters.
7. Component load per 13" Reel : 800 pcs.

P/N:CA32**M13*0		P/N:CA32**M13*L		Dimension			Packing (Reel/Caton)
Circuits		E	F	W1	W2	W3	
4~8	4~8	24.0(.945)	-	24.5(.965)	30.5(1.201)	24.5(.965)	9
10~14	10	32.0(1.260)	28.40(1.118)	32.5(1.280)	38.5(1.516)	32.5(1.280)	7
16~22	12~20	44.0(1.732)	40.40(1.596)	44.5(1.752)	50.5(1.988)	44.5(1.752)	5
24~26	22~26	56.0(2.205)	52.40(2.063)	56.5(2.224)	62.5(2.461)	56.5(2.224)	4

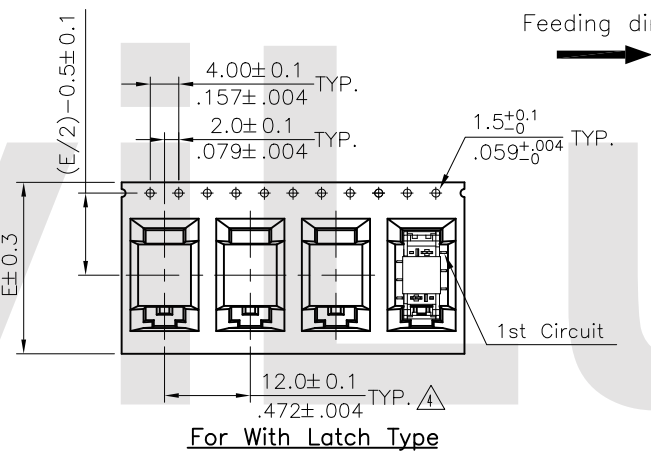
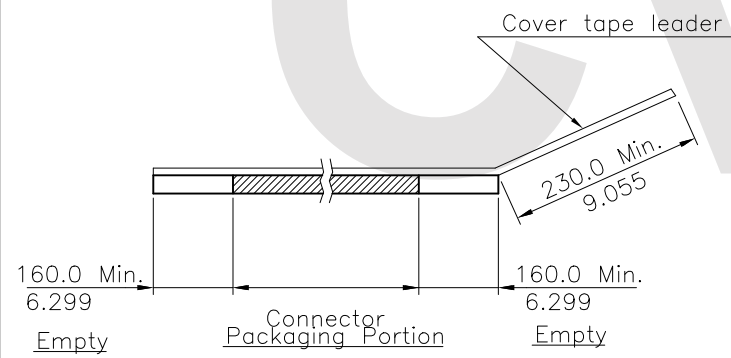

For With Latch Type

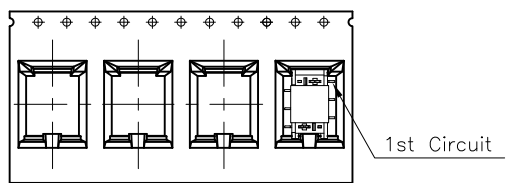

For Without Latch Type

WIDTH : 24 mm Carrier

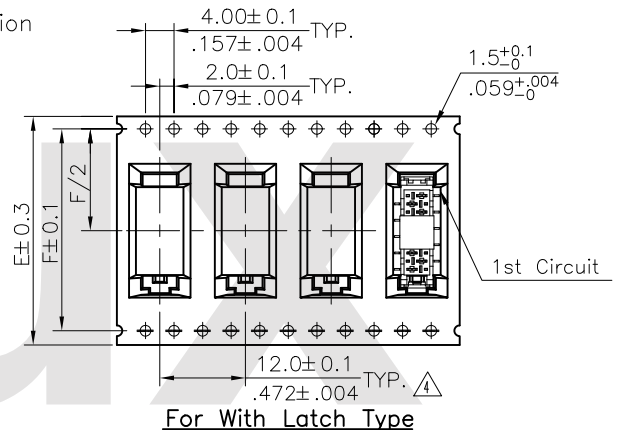

For With Latch Type

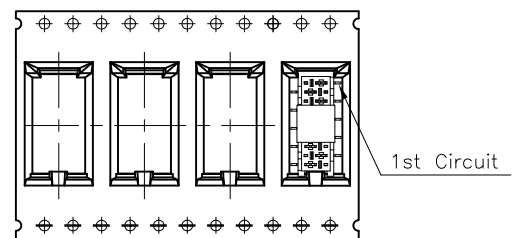

For Without Latch Type

WIDTH : 32.44.56 mm Carrier

RoHS Compliant

CVILUX CORP
2016.12.01
ISSUED

SYM	NAME	DATE	REVISIONS	APPROVED BY:	DATE	UNIT: mm / inch	TITLE: 1.27mm Pitch Female Top entry SMT Type Connector	MATERIAL:	FINISH:	DRAWING NO.	PART NO.	SHEET	OF
6	Sun	3/11-16'	ECRT116009/ECNT116035										
5	Sun	5/04-12'	ECN12080-0/ECR12003-1	DRAWN BY:	Sun	11/21-16'							
4	Sun	7/28-10'	ECN10269/ECR10097-0	ENGINEER:	Sun	11/21-16'							
3	Sandy	4/02-08'	ECN08159	CHECKED BY:	Eisley	11/25-16'							
				APPROVED BY:	Eisley	11/25-16'				CA3203SH	CA32**M13**	2	2

瀚荃股份有限公司
CviLux Corporation