

Material:

* Insulation:

High filled polyester UL 94V-0

* Contact: Phosphor Bronze

* Pick & Place Pad:

Nylon 6T UL 94V-0 Color Nature

DIM.A= 1.27 x No. of Spaces

DIM.B= DIM.A + 3.3

ORDERING CODE:

CA30 ** M 1 3 **
 ① ② ③ ④ ⑤ ⑥

- ① Series NO.:
- ② NO. OF CIRCUITS: 04 TO 26
- ③ Contacts TYPE: M= SMT
- ④ Plating option:
1= Tin over Nickel(Matte)
- ⑤ Color: 3= Red
- ⑥ Packing options:
R0=With PAD Tape & Reel
RN=Without PAD Tape & Reel
T0=Without PAD & Tube Packing

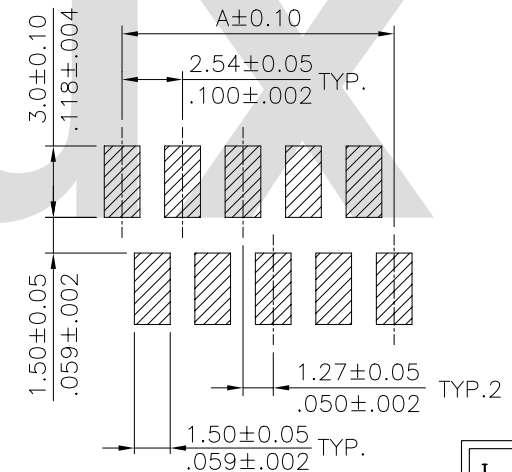
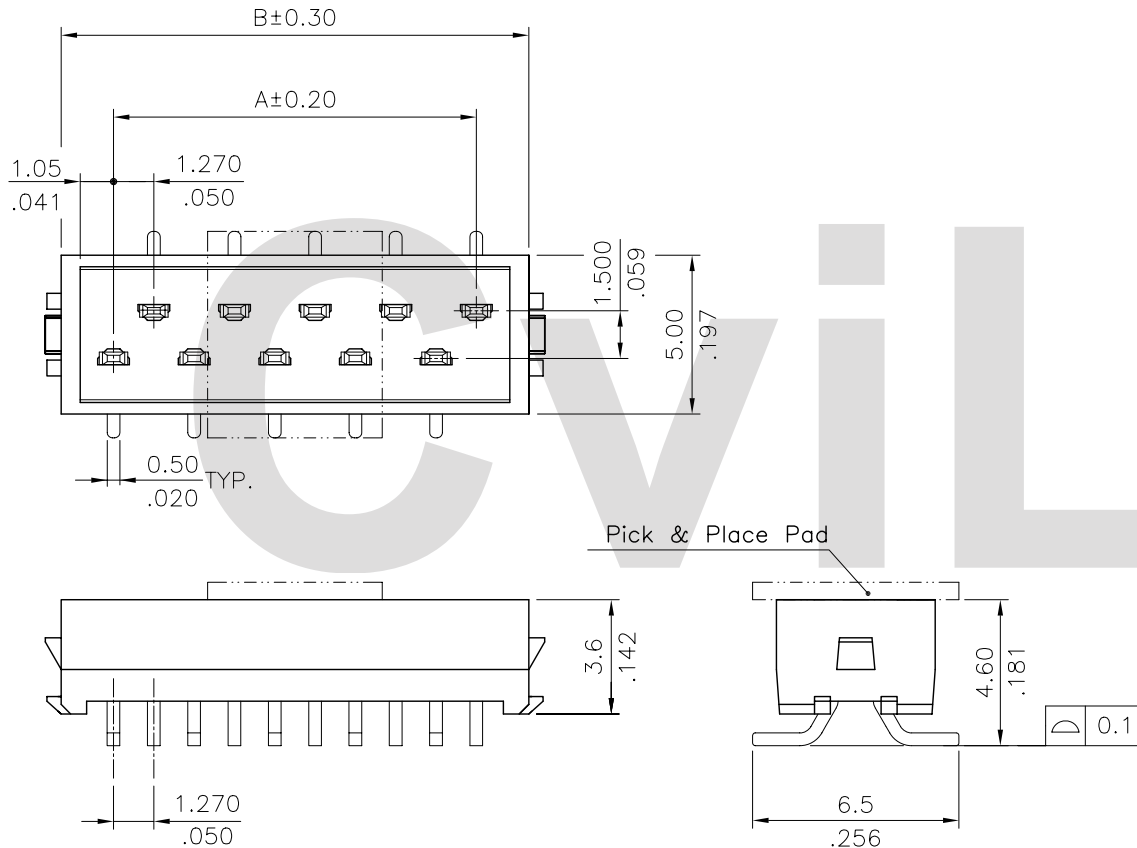

Lead Free Process

RoHS Compliant

④						DATE	UNIT: mm / inch	TITLE:	瀚荃股份有限公司 CviLux Corporation	
③			DRAWN BY:		Eager	06/29-07'	TOLERANCE UNLESS OTHERWISE SPECIFIED	CA30 SERIES SMT TYPE		
②	Eager	04/09-07'	ECN07259		ENGINEER:	Eisley	06/29-07'	.X ± 0.30/.012 X' ± 1'		MATERIAL:
①	Eager	04/09-07'	ECN07135		CHECKED BY:	Eisley	06/29-07'	.XX ± 0.20/.008 .X' ±		FINISH:
SYM	NAME	DATE	REVISIONS		APPROVED BY:	Alex	06/29-07'	.XXX ± 0.10/.004 .XX' ±		DRAWING NO. CA3007SB PART NO. CA30**M13**
									SCALE 4 / 1 SHEET 1 OF 2	

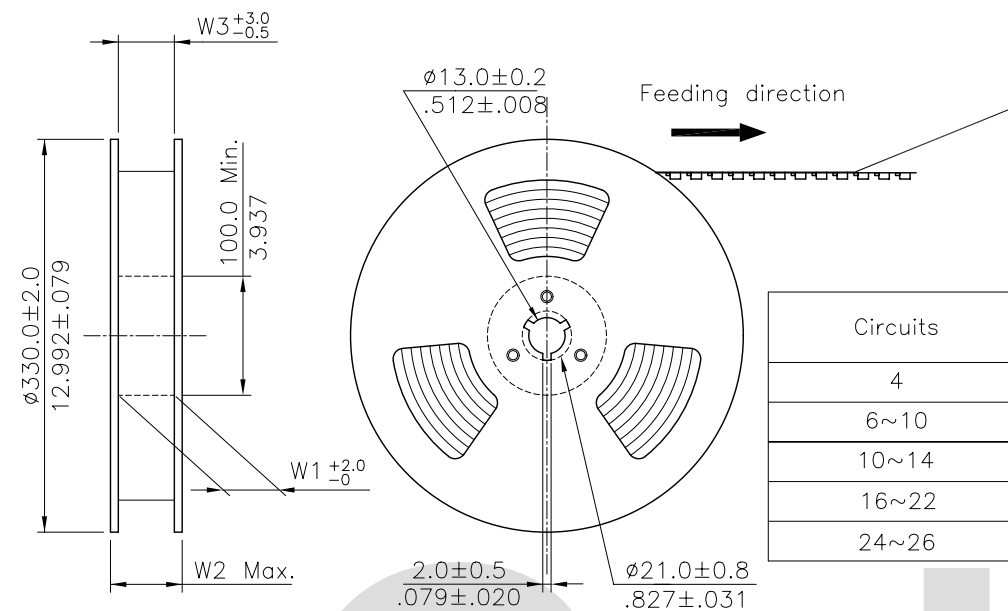

NOTES:

1. 10 sprocket hole pitch cumulative tolerance $\pm 0.20\text{mm}$.
2. Carrier camber not to exceed 1 mm in 100 mm.
3. Material :Transparent Anti-static Polysyrene.
4. All dimensions meet EIA-481-3 requirements.
5. Thickness : $0.40\pm 0.05\text{mm}$.
6. Packing length per 22" Reel : 30.6 Meters.
7. Component load per 13" Reel :1000 pcs.

Circuits	Dimension					Packing (Reel/Caton)
	E	F	W1	W2	W3	
4	16.0(.630)	-	16.5(.650)	22.5(.886)	16.5(.650)	11
6~10	24.0(.945)	-	24.5(.965)	30.5(1.201)	24.5(.965)	9
10~14	32.0(1.260)	28.40(1.118)	32.5(1.280)	38.5(1.516)	32.5(1.280)	7
16~22	44.0(1.732)	40.40(1.596)	44.5(1.752)	50.5(1.988)	44.5(1.752)	5
24~26	56.0(2.205)	52.40(2.063)	56.5(2.224)	62.5(2.461)	56.5(2.224)	4

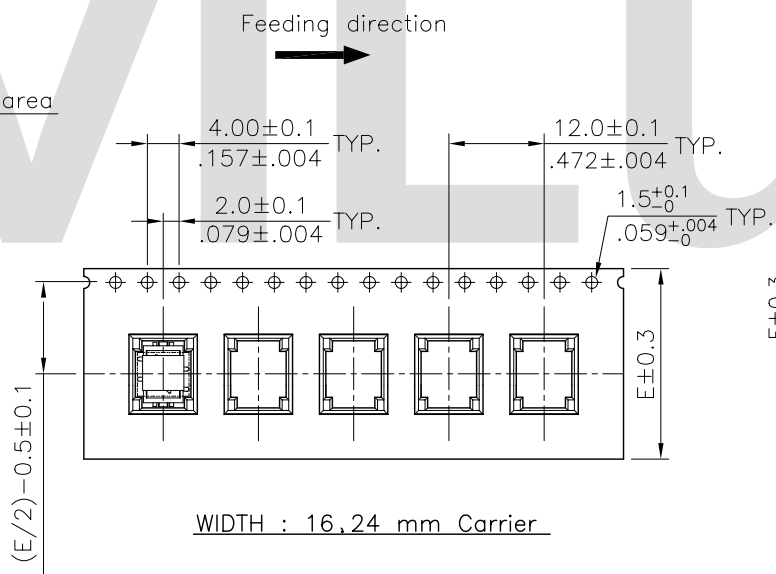
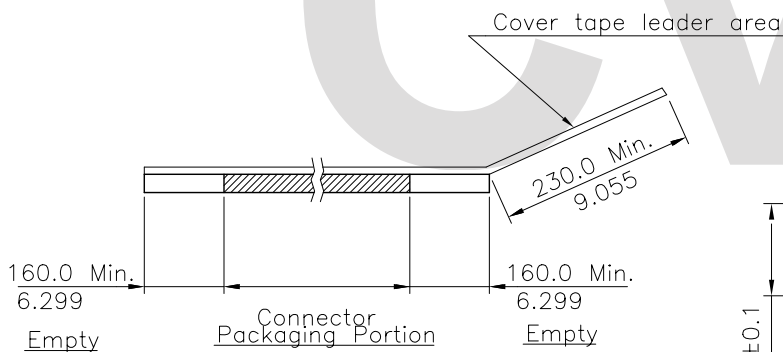

WIDTH : 16,24 mm Carrier

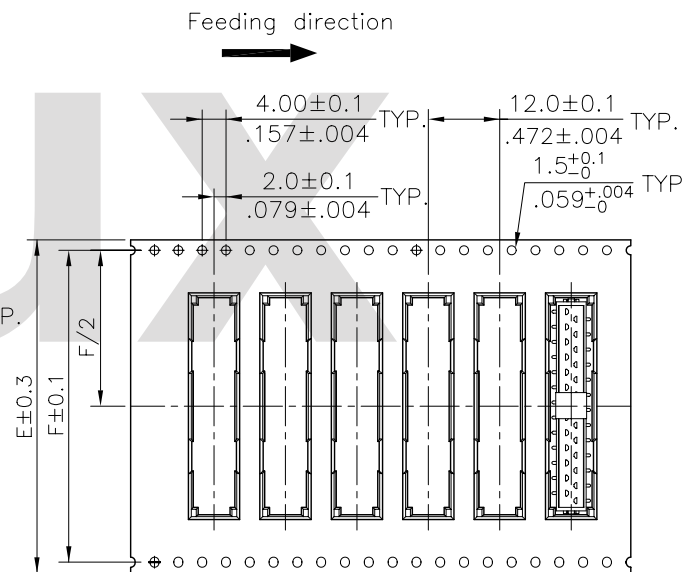

WIDTH : 32.44.56 mm Carrier

RoHS Compliant

4																			
3																			
2	Eager	04/09-07'	ECN07259		DRAWN BY:	Eager	06/29-07'	UNIT: mm / inch		TITLE: TAPE & REEL PACKAGING FOR CA30 SERIES SMT TYPE	MATERIAL:	DRAWING NO. CA3007SB	PART NO.	SCALE	SHEET 2 OF 2				
1	Eager	04/09-07'	ECN07135		ENGINEER:	Eisley	06/29-07'	TOLERANCE UNLESS OTHERWISE SPECIFIED											
					CHECKED BY:	Eisley	06/29-07'	.X ±	.X' ± 1'										
					APPROVED BY:	Alex	06/29-07'	.XX ±	.X' ±										

瀚荃股份有限公司
CviLux Corporation