

Material:
 Insulator: Glass filled Polyester UL 94V-0
 Color Block or Green
 Shell: Steel, Tin plated as standard
 High power Contact :
 Brass with Gold plated

Ordering Code

C3W3 P P V 3 0 1 40 D00
 ① ② ③ ④ ⑤ ⑥ ⑦ ⑧ ⑨

- ① Series No.
- ② Connector Type: P= Plug
- ③ Contact type: P= High Power Contact
- ④ Contact tail style: V= Straight Dip type
- ⑤ High power contact plating:
 2= Gold flash plated over Nickel
 3= 15μ" Gold plated over Nickel
 4= 30μ" Gold plated over Nickel
 5= 50μ" Gold plated over Nickel
- ⑥ Singal contact plating:
 0= Without singal contact
- ⑦ Insulator color: 1= Black, 6= Green
- ⑧ Performance: 40= 40A
- ⑨ Mounting Style:
 000= With ø3.05mm holes on shell
 B00= Riveted #4-40 UNC open nuts on front shell
 C00= Riveted #4-40 UNC open nuts on rear shell
 D00= Riveted #4-40 UNC ground stand-off on rear shell(standard)

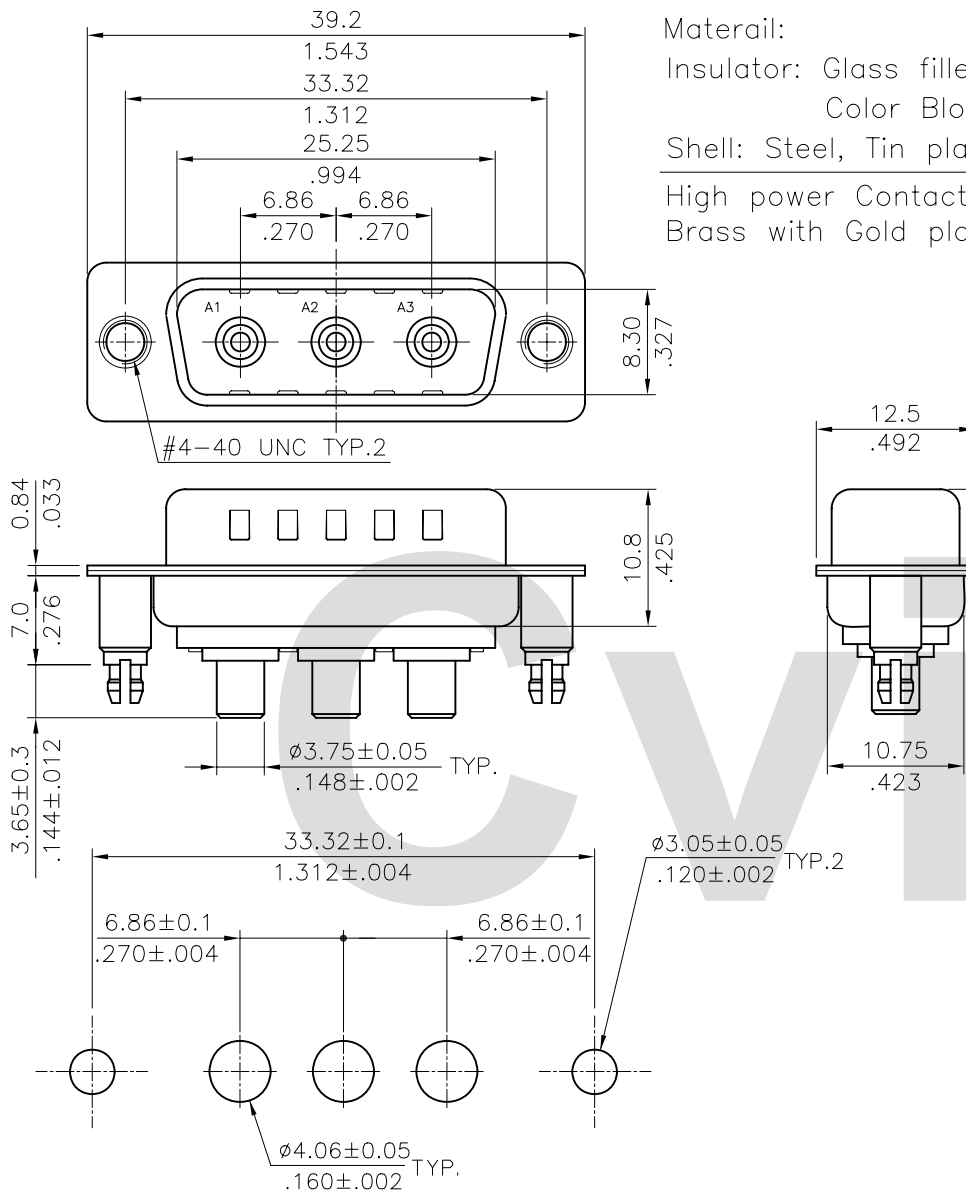

Recommended P.C Board Layout

Mounting Style				RoHS Compliant			
Code	000	Code	B00	Code	C00	Code	D00
			DIM. L= 4.0mm		DIM. L= 4.0mm		DIM. L= 7.0mm

4				DATE	UNIT: mm / inch	TITLE: C3W3 40A HIGH POWER MALE D-SUB CONNECTOR (TOP ENTRY BOARD MOUNT TYPE)	瀚荃股份有限公司 CviLux Corporation
3			DRAWN BY: Rita	10/18-01'	TOLERANCE UNLESS OTHERWISE SPECIFIED	MATERIAL:	
2			ENGINEER: David	10/18-01'	.X ± 0.30/012 X: ± 1'	DRAWING NO. C3W309SB PART NO. C3W3PPV*0*40***	
1			CHECKED BY: David	10/18-01'	.XX ± 0.20/008 .X ±		
			APPROVED BY: Alex	10/18-01'	.XXX ± 0.10/004 .XX ±		
SYM	NAME	DATE	REVISIONS			FINISH:	SCALE 2 / 1 SHEET 1 OF 1

