

Material:

- \* Insulation: Nylon 6T UL 94V-0  
Color Black
- \* Contact: Brass

CIRCUITS	DIM. A	DIM. B	DIM. C
2	—	6.7(.264)	3.0(.118)
4	3.00(.118)	9.7(.382)	3.0(.118)
6	6.00(.236)	12.7(.500)	3.0(.118)
8	9.00(.354)	15.7(.618)	7.7(.303)
10	12.00(.472)	18.7(.736)	10.7(.421)
12	15.00(.591)	21.7(.854)	13.7(.539)
14	18.00(.709)	24.7(.972)	16.7(.657)
16	21.00(.827)	27.7(1.091)	19.7(.776)
18	24.00(.945)	30.7(1.209)	22.7(.894)
20	27.00(1.063)	33.7(1.327)	25.7(1.012)
22	30.00(1.181)	36.7(1.445)	28.7(1.130)
24	33.00(1.299)	39.7(1.563)	31.7(1.248)

Ordering Code:

CP35 ① ② ③ ④ ⑤ ⑥ ⑦ ⑧ -LF

- ① Series No.
- ② No. of Circuits: 02~24
- ③ Contact type: P= Plug
- ④ Contact plated:
  - 1= Matte Tin Plated over Nickel
  - A= Selective Gold Flash Plated over 1.27μm(50μ") Nickel
  - B= Selective 0.38μm(15μ") Gold Plated over 1.27μm(50μ") Nickel
  - C= Selective 0.76μm(30μ") Gold Plated over 1.27μm(50μ") Nickel
- ⑤ H= Right angle type
- ⑥ Mount type: S= SMT Type
- ⑦ Other options:
  - P= With plastic board lock
- ⑧ LF= For Lead Free IR Process

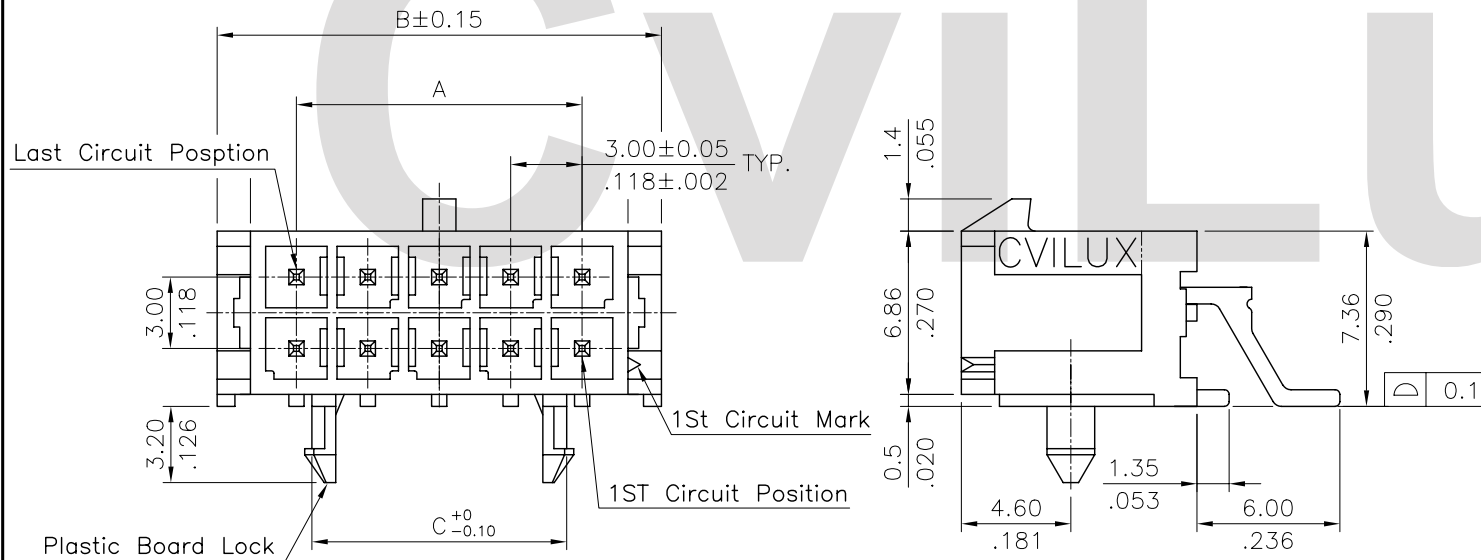

Lead Free Process      RoHS compliant

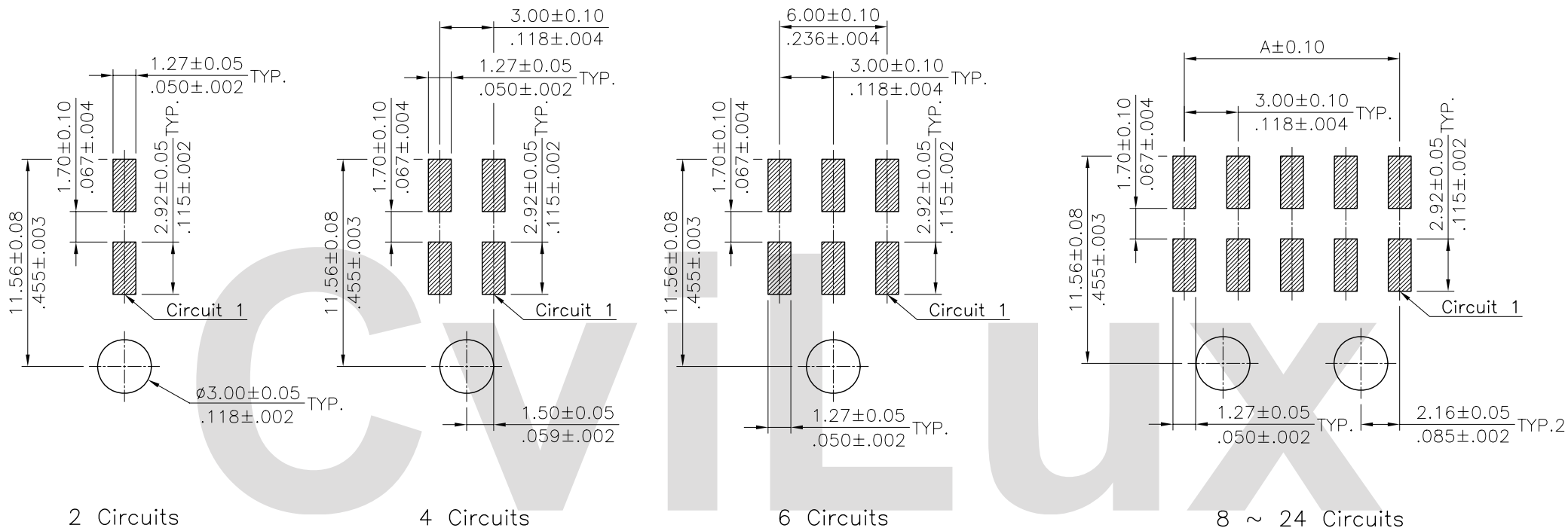

<table border="1"> <tr><td>④</td></tr> <tr><td>③</td></tr> <tr><td>②</td></tr> <tr><td>①</td></tr> </table>	④	③	②	①		DRAWN BY: Karen ENGINEER: Eisley CHECKED BY: Eisley APPROVED BY: Alex	DATE: 2/27-09'	UNIT: mm / inch	TITLE: 3.00mm PITCH RIGHT ANGLE SMT TYPE POWER CONN.  MATERIAL:  FINISH:		DRAWING NO. CP3597SA    PART NO. CP35**P*HSP-LF
	④										
	③										
	②										
①											
TOLERANCE UNLESS OTHERWISE SPECIFIED	.X ± 0.30/.012    .X' ± 1'										
.XX ± 0.20/.008    .X' ±											
.XXX ± 0.10/.004    .XX' ±											
SYM	NAME	DATE	REVISIONS	SCALE: 3 / 1	SHEET: 1 OF 2						



Recommended P.C. Board Layout

Lead Free Process

RoHS compliant

4				 <b>2009.03.10</b> <b>ISSUED</b>		DATE	UNIT: mm / inch	TITLE: 3.00mm PITCH RIGHT ANGLE SMT TYPE POWER CONN.	 瀚荃股份有限公司 CviLux Corporation
3			DRAWN BY: Karen		2/27-09'	TOLERANCE UNLESS OTHERWISE SPECIFIED		MATERIAL:	
2			ENGINEER: Eisley		3/02-09'	.X ± 0.30/.012 X' ± 1'		FINISH:	
1			CHECKED BY: Eisley		3/02-09'	.XX ± 0.20/.008 .X' ±		DRAWING NO. CP3597SA	PART NO. CP35**P*HSP-LF
SYM	NAME	DATE	REVISIONS		APPROVED BY: Alex	3/02-09'	.XXX ± 0.10/.004 .XX' ±	SCALE 3 / 1	SHEET 2 OF 2