

Material :

- * Base:
High Temperature Plastic UL 94V-0
Color Nature (Halogen-Free)
- * Contact :
Phosphor Bronze, With Tin plated
- * Tab :
Brass, With Tin plated

Ordering Code:

CIL4 02 M 1 H R 0 -NH
① ② ③ ④ ⑤ ⑥ ⑦ ⑧

- ① Series No.
- ② No. of Circuits: 02 Pin
- ③ M= SMT Type
- ④ Plating: 1= 3.05um(120u")~4.88um(192u")
Matte Tin over
1.27um(50u") Nickel
- ⑤ Type: H= Side Entry
- ⑥ Packing Options: R= Tape & Reel packing
- ⑦ Option: 0= Standard
- ⑧ Other option:
-NH= For Lead Free IR Processes
and Halogen-Free

Halogen-Free

Lead Free Process

RoHS compliant

④						DATE	UNIT: mm / inch	TITLE:	 瀚荃股份有限公司 CviLux Corporation		
③			DRAWN BY:		Clark	5/6-15'	TOLERANCE	CL4 series connector			
②			ENGINEER:		Clark	5/6-15'	UNLESS OTHERWISE SPECIFIED	MATERIAL:			
①	Clark	05/06-15	CHECKED BY:		David	5/8-15'	.X ± 0.30/.012 X: ± r	FINISH:			
SYM	NAME	DATE	REVISIONS	APPROVED BY:	David	5/8-15'	.XX ± 0.20/.008 X: ±	DRAWING NO.	CIL401SA	PART NO.	CIL402M1HRO-NH
							.XXX ± 0.10/.004 XX: ±	SCALE	5 / 1	SHEET	1 OF 3

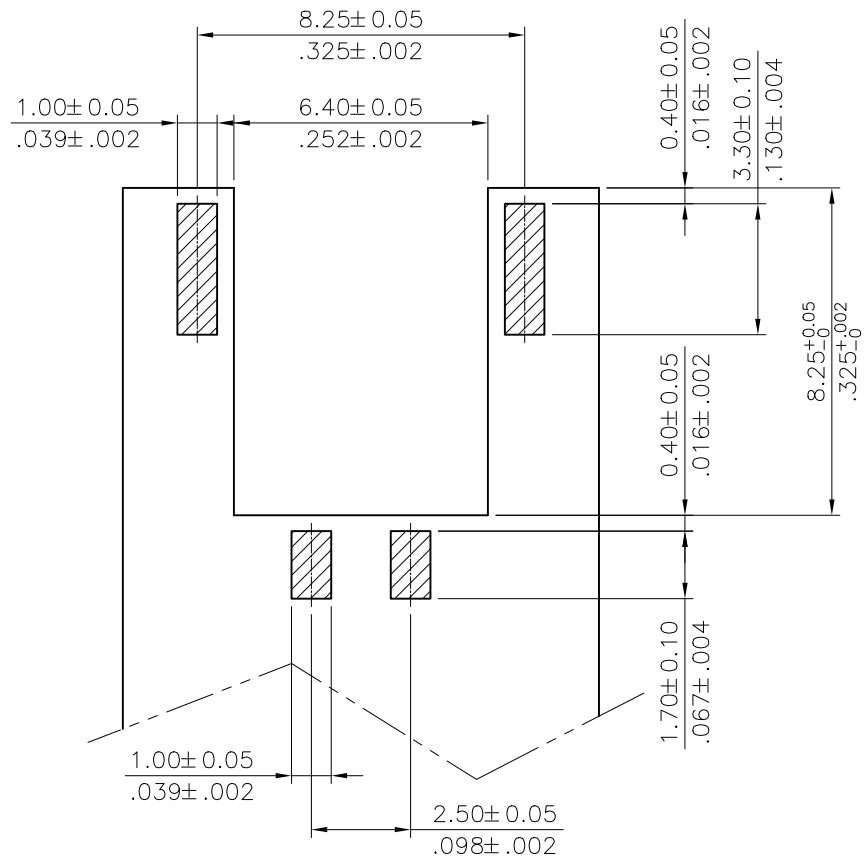

Recommended P.C.B Layout

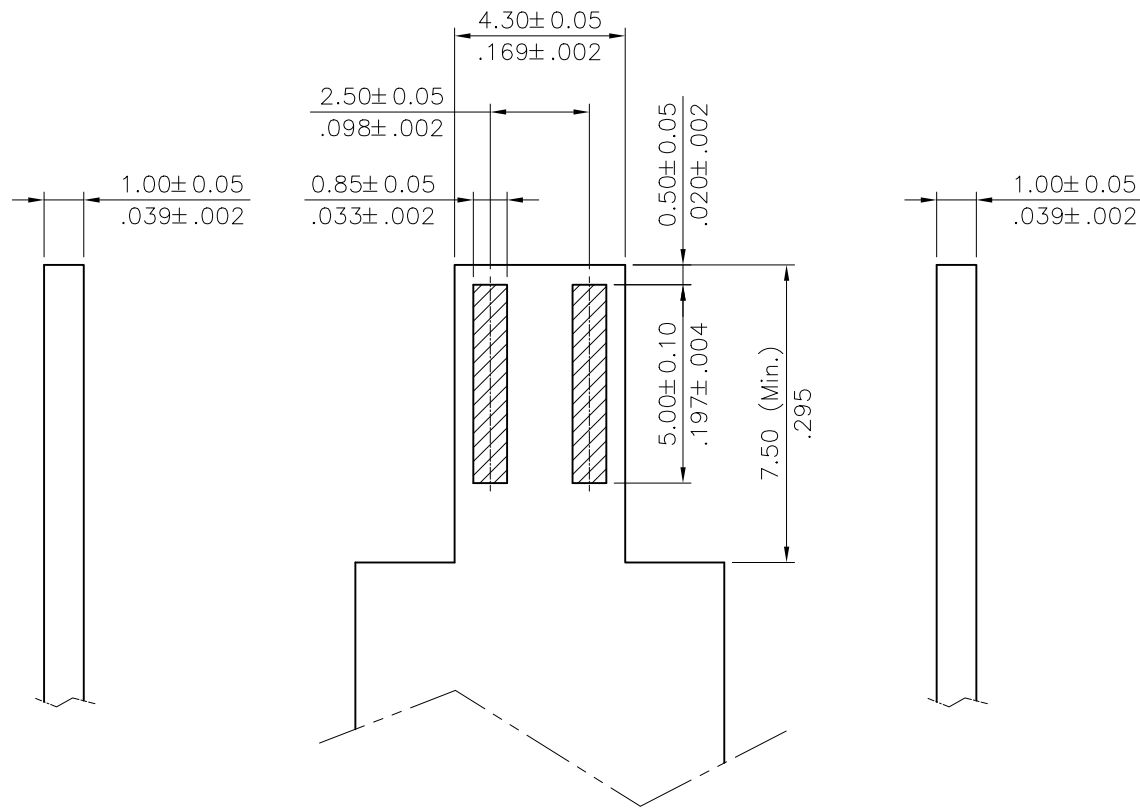

Recommended FR4 Layout

Halogen-Free Lead Free Process RoHS Compliant

4						DATE	UNIT: mm / inch	TITLE:	 瀚荃股份有限公司 CviLux Corporation	
3			DRAWN BY:		Clark	5/6-15'	TOLERANCE UNLESS OTHERWISE SPECIFIED			CIL4 series connector
2			ENGINEER:		Clark	5/6-15'	.X ± 0.30/.012	X' ± r		MATERIAL:
1	Clark	05/06-15	ECNT115097		CHECKED BY:	David	5/8-15'	.XX ± 0.20/.008		X' ±
SYM	NAME	DATE	REVISIONS	APPROVED BY:	David	5/8-15'	.XXX ± 0.10/.004	.XX' ±	DRAWING NO. CIL401SA	PART NO. CIL402M1HR0-NH
									SCALE 5 / 1	SHEET 2 OF 3

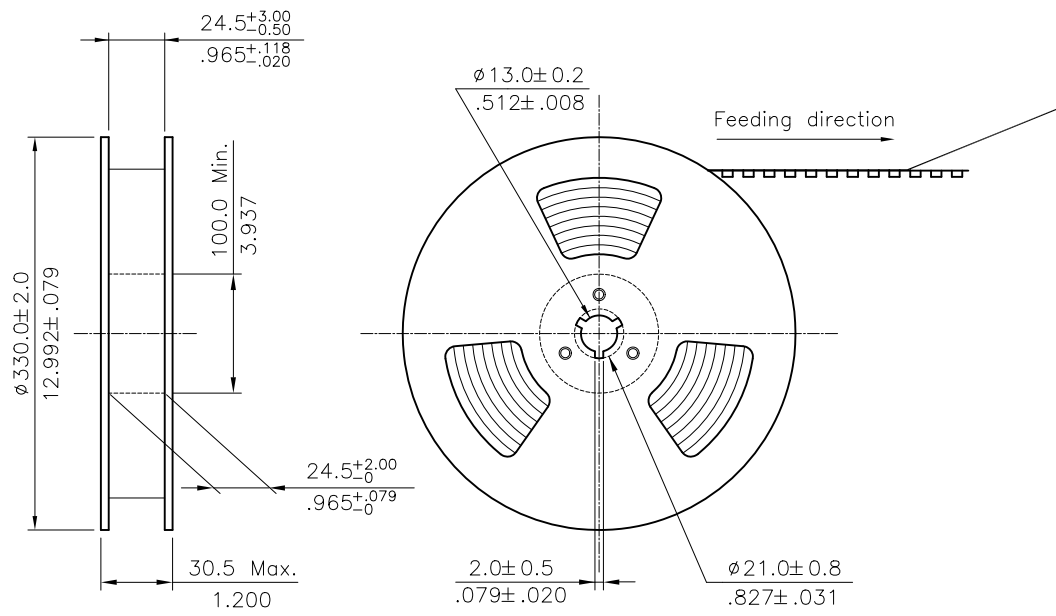

NOTE :

- * Reel Material : Corrugated Paper
- * Carrier Material : Clear, Conductive Polystyrene Alloy
- * Cover Tape Material : Polyester
- * Cover Tape Peel Strength : 0.1N – 1.3N
- * Carrier camber is within 1mm in 100mm
- * All dimensions meet EIA-481-2 & EIA-481-3 requirements.
- * Quantity : 900 PCS/Reel
- * Packing : 9 Reel/Carton

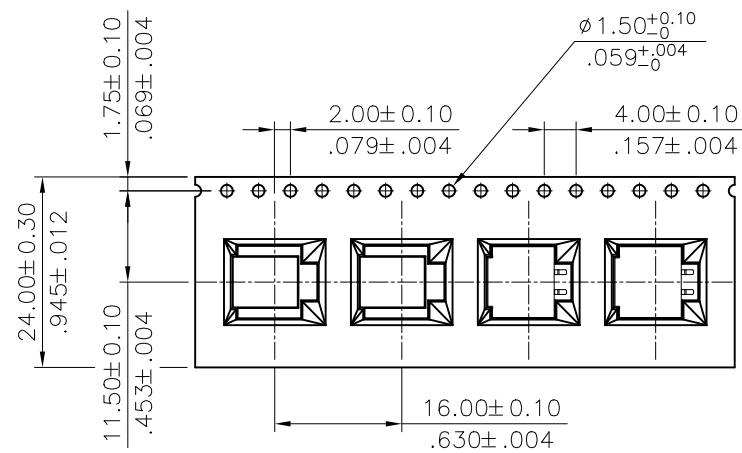
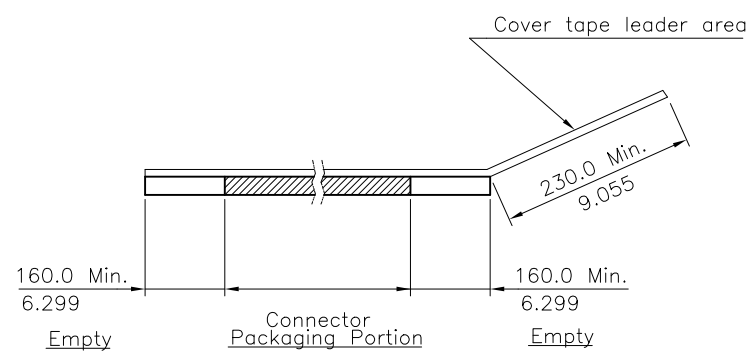

WIDTH : 24 mm Carrier

RoHS Compliant

4						DATE	UNIT: mm / inch	TITLE:	瀚荃股份有限公司 CviLux Corporation	
3			DRAWN BY: Clark		5/6-15'	TOLERANCE UNLESS OTHERWISE SPECIFIED		MATERIAL:		
2			ENGINEER: Clark		5/6-15'	.X ±	X' ±	FINISH:		
1	Clark	05/06-15	ECNT115097		CHECKED BY: David	5/8-15'	.XX ±	.X ±	DRAWING NO. CIL401SA	PART NO. CIL402M1HR0-NH
SYM	NAME	DATE	REVISIONS		APPROVED BY: David	5/8-15'	.XXX ±	.XX ±	SCALE	SHEET 3 OF 3