

Notes:

- * Base: High Temperature Plastic UL 94V-0 Color Black (Halogen-Free)
 - * Contact : Copper Alloy
 - * Shell : Stainless Steel
- solder area gold flash over nickel

Ordering Code:

CI99 ** M 2 H R 0 -NH
 ① ② ③ ④ ⑤ ⑥ ⑦ ⑧

- ① Series No.
- ② No. of Circuits: 06 ~ 10 Pin
- ③ M= SMT Type
- ④ Plating: 2= 0.03um(1.2u") Min. Gold Flash Plating on Contact area and Solder tails, 1.27um(50u") Nickel Underplating over all
- ⑤ Type: H= Side entry
- ⑥ Packing Options: R= Tape & Reel packing
- ⑦ Option: 0= Standard
- ⑧ Other option:
-NH= For Lead Free IR Processes and Halogen-Free

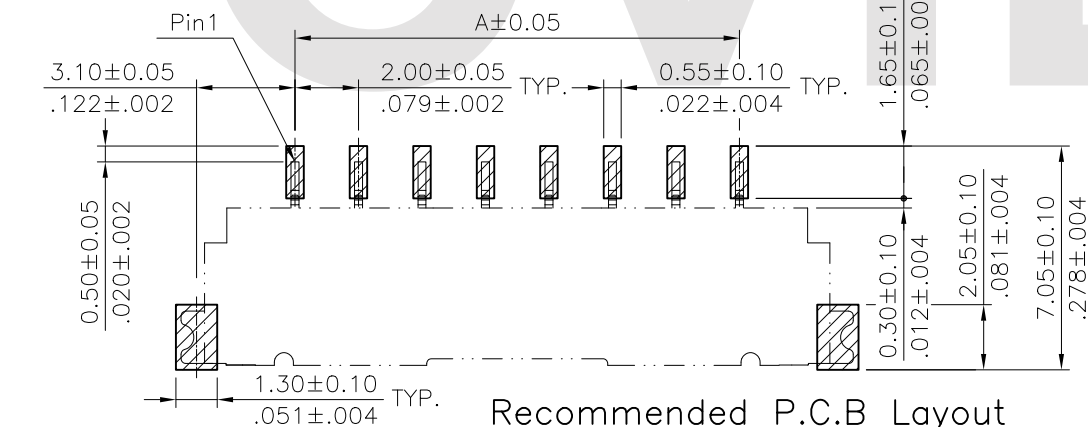
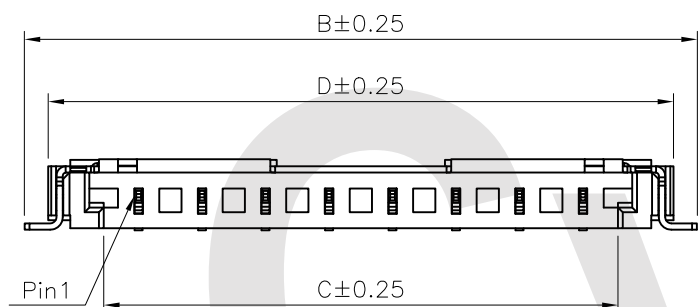

Recommended P.C.B Layout

Circuits	Dimension			
	A	B	C	D
06	10.00(.394)	17.2(.677)	12.2(.480)	15.7(.618)
07	12.00(.472)	19.2(.756)	14.2(.559)	17.7(.697)
08	14.00(.551)	21.2(.835)	16.2(.638)	19.7(.776)
09	16.00(.630)	23.2(.913)	18.2(.717)	21.7(.854)
10	18.00(.709)	25.2(.992)	20.2(.795)	23.7(.933)

Halogen-Free

Lead Free Process

RoHS compliant

SYM	NAME	DATE	REVISIONS	APPROVED BY:	DATE
④					
③	Clark	12/09-15	ECNT115263	CLARK	12/09-15'
②	Karen	12/25-14'	ECNT114252/ECRT114090	CLARK	12/09-15'
①	Clark	05/06-14	ECNT114087	EISLEY	12/14-15'

CVILUX CORP
2015.12.17
ISSUED

UNIT:	mm / inch
TOLERANCE UNLESS OTHERWISE SPECIFIED	
.X ± 0.25/.010	X' ± r'
.XX ± 0.15/.006	.X' ±
.XXX ± 0.10/.004	.XX' ±

TITLE:	
MATERIAL:	
FINISH:	



瀚荃股份有限公司
 CviLux Corporation

DRAWING NO.	CI9901SC	PART NO.	CI99**M2HRO-NH
SCALE	4 / 1	SHEET	1 OF 2

NOTE :

- * Reel Material : Corrugated Paper
- * Carrier Material : Black, Conductive Polystyrene Alloy
- * Cover Tape Material : Polyester
- * Cover Tape Peel Strength : 0.1N – 1.3N
- * Carrier camber is within 1mm in 100mm
- * All dimensions meet EIA-481-2 & EIA-481-3 requirements.
- * Quantity : 1800 PCS/Reel

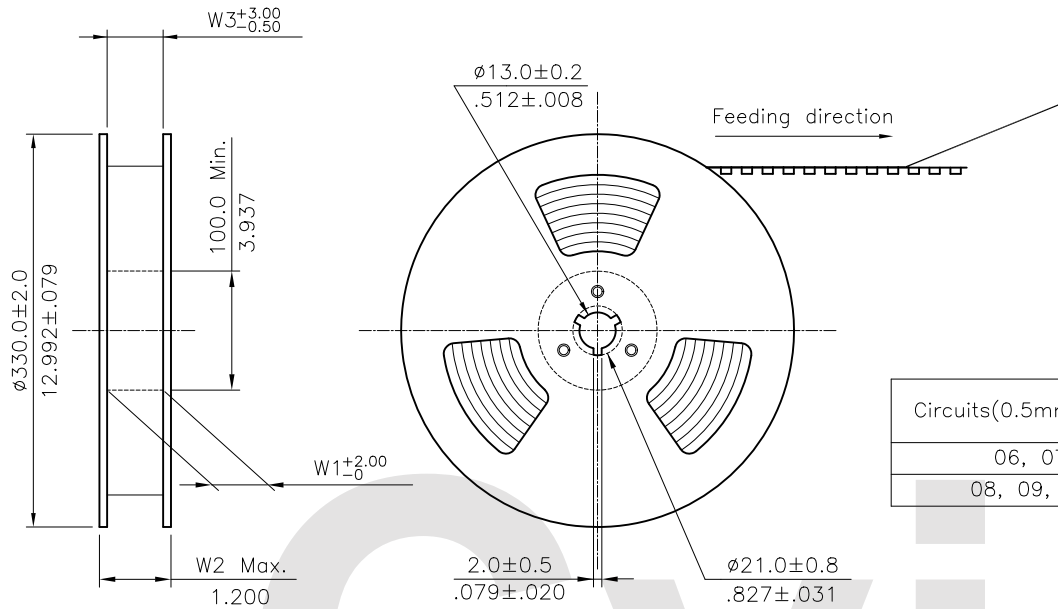

Circuits(0.5mm Pitch)	Dimension					Packing (Reel/Caton)
	E	F	W1	W2	W3	
06, 07	32.0(1.260)	28.40(1.118)	32.5(1.280)	38.5(1.516)	32.5(1.280)	7
08, 09, 10	44.0(1.732)	40.40(1.596)	44.5(1.752)	50.5(1.988)	44.5(1.752)	5

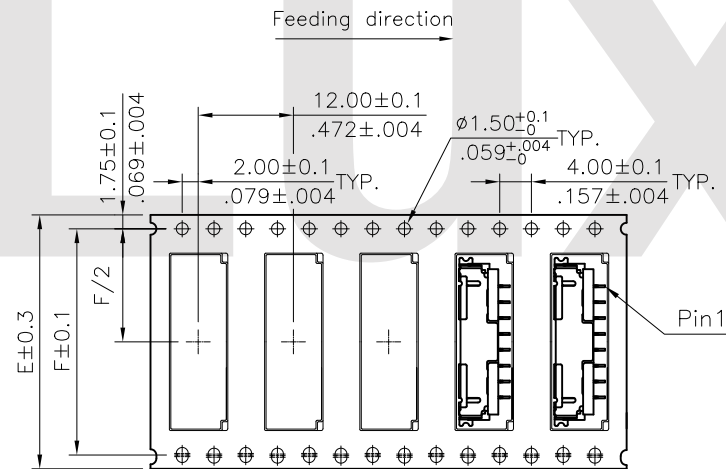
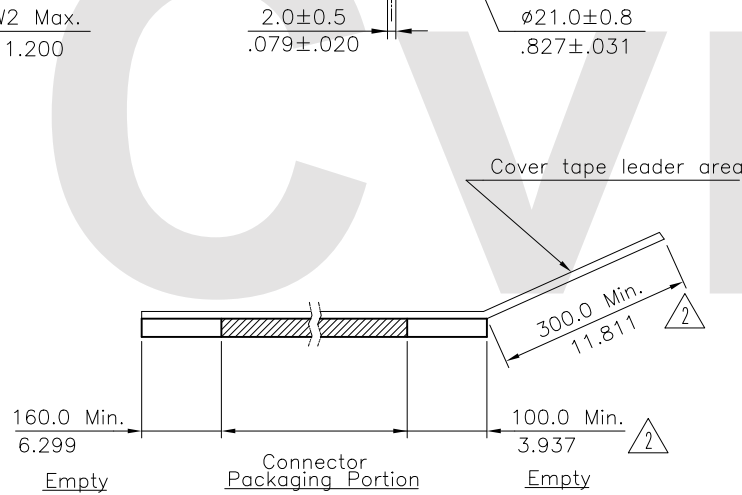

WIDTH : 32.44 mm Carrier

RoHS Compliant

SYM	NAME	DATE	REVISIONS	APPROVED BY:	DATE	UNIT: mm / inch	TITLE:	MATERIAL:	FINISH:	DRAWING NO. CI9901SC	PART NO. CI99**M2HRO-NH
4											
3	Clark	12/09-15	ECNT115263	DRAWN BY: Clark	12/09-15'	TOLERANCE UNLESS OTHERWISE SPECIFIED .X ± 0.25/.010 X' ± r' .XX ± 0.15/.006 X' ± .XXX ± 0.08/.003 XX' ±	TITLE:	MATERIAL:	FINISH:	DRAWING NO. CI9901SC	PART NO. CI99**M2HRO-NH
2	Karen	12/25-14'	ECNT114252/ECRT114090	ENGINEER: Clark	12/09-15'						
1	Clark	05/06-14	ECNT114087	CHECKED BY: Eisley	12/14-15'						
SYM	NAME	DATE	REVISIONS	APPROVED BY:	DATE					SCALE	SHEET 2 OF 2



瀚荃股份有限公司
CviLux Corporation