

SEC. E-E

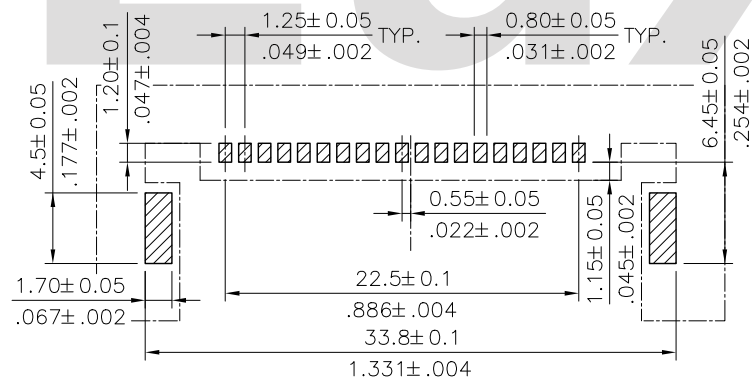
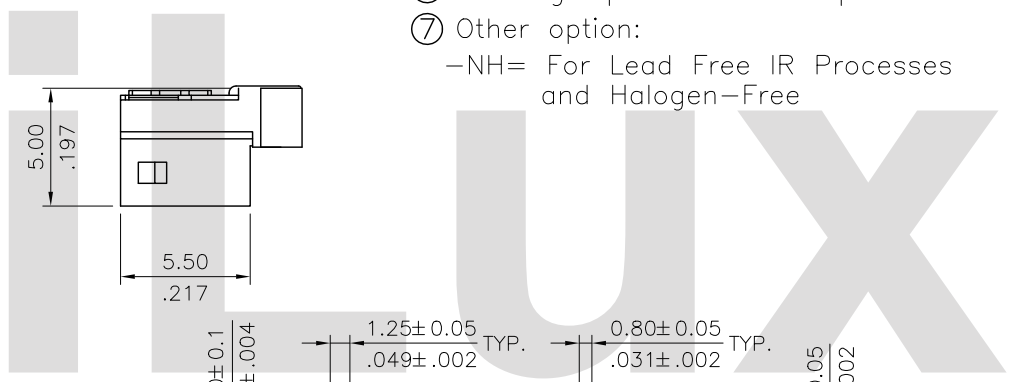
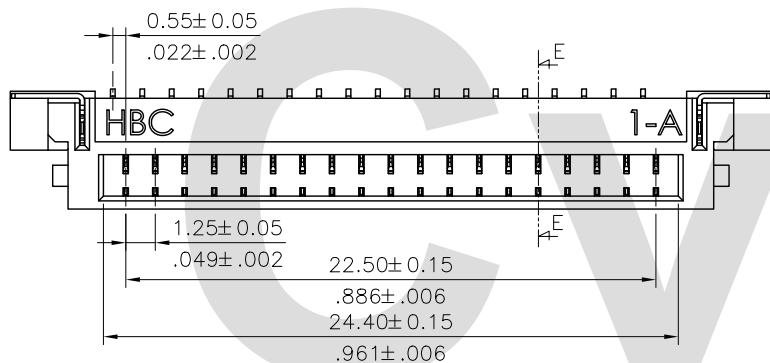

Recommended P.C. Board Layout

Ordering Code:

CI45 19 M 1 H R0 - NH
 ① ② ③ ④ ⑤ ⑥ ⑦

- ① Series No.
- ② No. of Circuits: 19 Pin
- ③ M= SMT type header
- ④ Plating: 1= 3.05um(120u") ~ 4.88um(192u")
Matte Tin over 1.27um(50u") Nickel
- ⑤ Type: H= Side Entry
- ⑥ Packing Options: R0= Tape & Reel packing
- ⑦ Other option:
-NH= For Lead Free IR Processes
and Halogen-Free

Halogen-Free

Lead Free Process

RoHS Compliant

④						DATE	UNIT: mm / inch	TITLE: 1.25mm Pitch WTB SMT R/A TYPE	 瀚荃股份有限公司 CviLux Corporation
③			DRAWN BY: Hank		6/21-12'	TOLERANCE UNLESS OTHERWISE SPECIFIED		MATERIAL:	
②			ENGINEER: Eisley		7/2-12'	.X ± 0.30/.012	.X' ± 1"	FINISH:	
①			CHECKED BY: Eisley		7/2-12'	.XX ± 0.20/.008	.X' ±		
SYM	NAME	DATE	REVISIONS	APPROVED BY: David	7/2-12'	.XXX ± 0.10/.004	.XX' ±		DRAWING NO. CI4501SA SCALE 3 / 1 PART NO. CI4519M1HR0-NH SHEET 1 OF 2

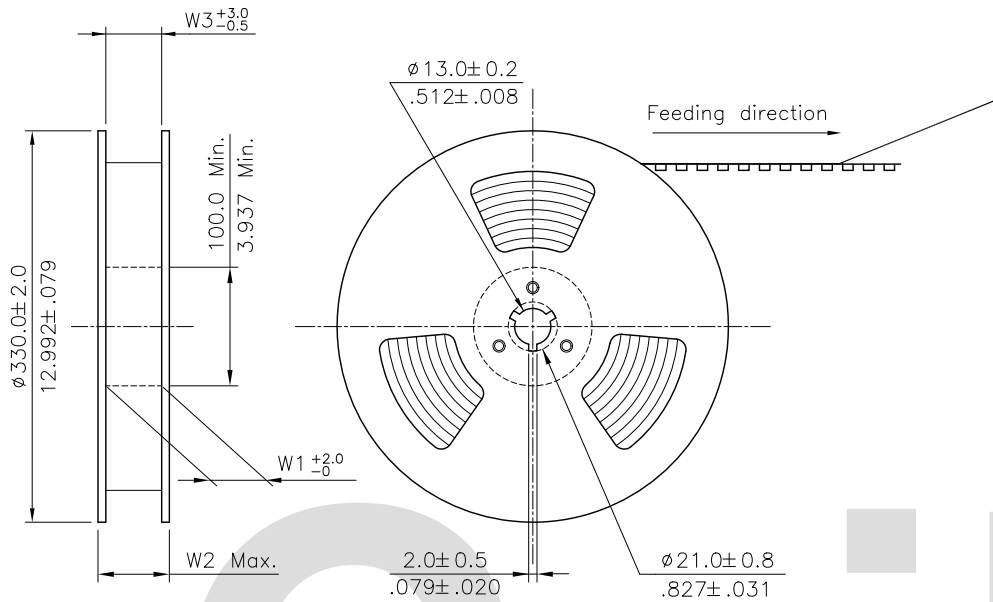

- NOTES:
1. 10 sprocket hole pitch cumulative tolerance ± 0.20
 2. Carrier camber is within 1 mm in 250 mm.
 3. Material :Transparent Anti-static Polysyrene.
 4. All dimensions meet EIA-481-C requirements.
 5. Thickness : 0.40 ± 0.05 mm.
 6. Packing length per 22" Reel : 39.36 Meters.
 7. Component load per 13" Reel : 700 pcs.

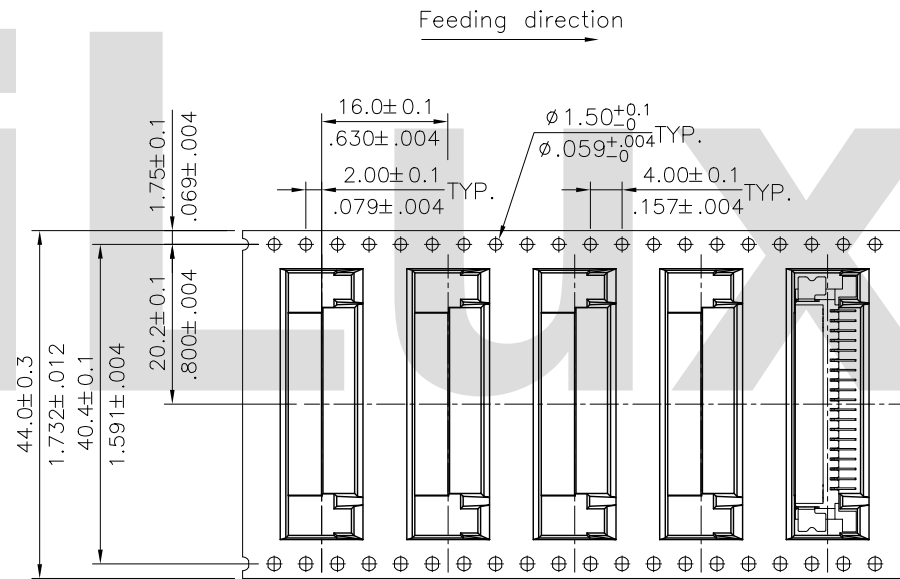
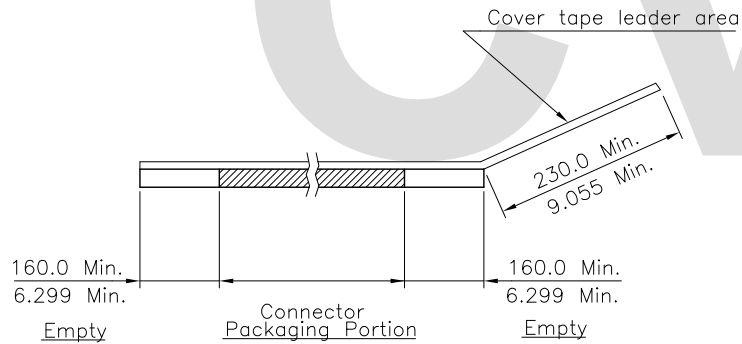

RoHS Compliant

CIVILUX CORP
2012.07.12
ISSUED

4				DATE	UNIT: mm / inch	TITLE: 1.25mm Pitch WTB SMT R/A TYPE	 瀚荃股份有限公司 CviLux Corporation		
3			DRAWN BY: Hank	6/21-12'	TOLERANCE UNLESS OTHERWISE SPECIFIED	MATERIAL:			
2			ENGINEER: Easley	7/2-12'	.X ±	.X' ± 1'	DRAWING NO. CI4501SA		
1			CHECKED BY: Easley	7/2-12'	.XX ±	.X' ±	PART NO. CI4519M1HRO-NH		
SYM	NAME	DATE	REVISIONS	APPROVED BY: David	7/2-12'	.XXX ±	.XX' ±	SCALE	SHEET 2 OF 2