

NOTE:

Material :

- * Base : High Temperature plastic UL 94V-0
Color Black
- * Contact : Copper alloy
- * Fixed tab : Matte Tin plated over Nickel

ORDERING CODE

CI43 06 M 1 H R D -NH
 ① ② ③ ④ ⑤ ⑥ ⑦ ⑧

- ① Series No.
- ② Contact: 06
- ③ M= SMT Type Header
- ④ Plating :
1 = 120u" Matte Tin plated over
50u" Nickel
- ⑤ Type : H= Side entry
- ⑥ Packing option:
R= Tape & Reel Packing
- ⑦ Other option:
D= Special Type
- ⑧ -NH= For Lead Free IR Processes and
Halogen-Free

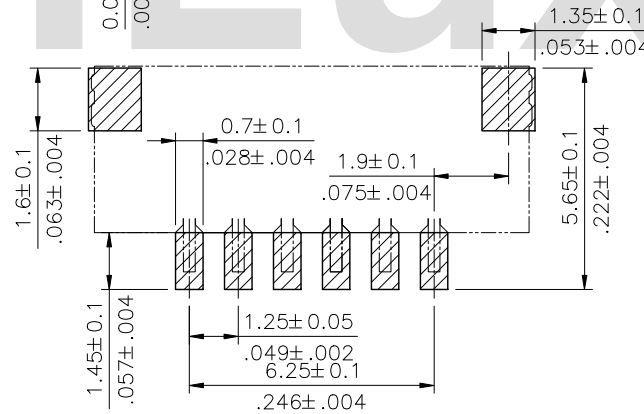
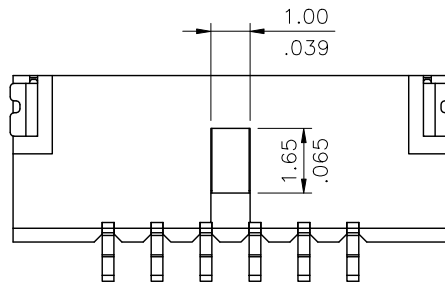
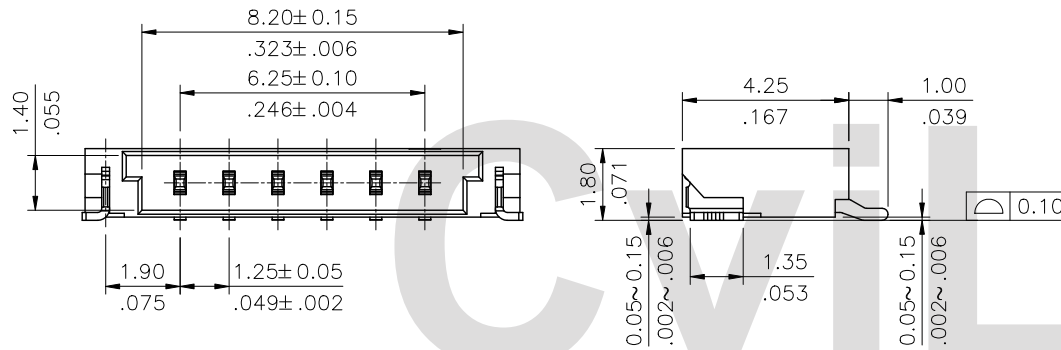

Recommended P.C. Board Layout

Halogen-Free

Lead Free Process

RoHS Compliant



④					DATE	UNIT: mm / inch	TITLE: 1.25mm Pitch WTB SMT R/A TYPE	瀚荃股份有限公司 CviLux Corporation
③				DRAWN BY: Hank	7/31-14'	TOLERANCE UNLESS OTHERWISE SPECIFIED	MATERIAL:	
②				ENGINEER: Eisley	7/31-14'	.X ± 0.30/.012 X' ± 1'	FINISH:	
①				CHECKED BY: Eisley	7/31-14'	.XX ± 0.20/.008 .X' ±		
SYM	NAME	DATE	REVISIONS	APPROVED BY: David	7/31-14'	.XXX ± 0.10/.004 .XX' ±		DRAWING NO. CI4313S1 PART NO. CI4306M1HRD-NH SCALE 6 / 1 SHEET 1 OF 2

