

Recommended P.C. Boarded Layout

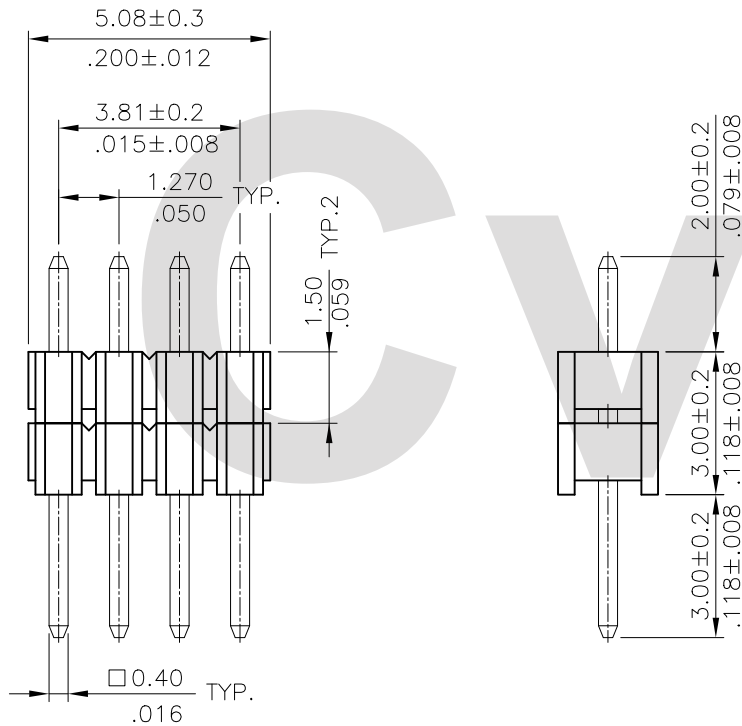

Notes:

* Material:

Insulator: Nylon 6T With 30% GF.

UL 94V-0 Color Black

Square Pin: Brass

* For Lead Free wave flow process

Ordering Code:

CH09 04 2 V 1 00

① ② ③ ④ ⑤ ⑥

① Series No.

② No. of Contact:

③ Plating code:

2=Gold Flash plated over
1.27µm(50u") Nickel

④ Tail & Mounting Style:
V=Straight DIP Type

⑤ Insulator Material & Color:
1=Nylon 6T , Color Black

⑥ Option Code:
00= Standard

Lead Free Process

RoHS Compliant

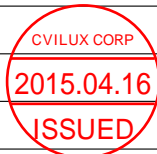

4					DATE	UNIT: mm / inch	TITLE: 1.27mm(.050") SINGLE ROW BOARD MOUNT PIN HEADER	 瀚荃股份有限公司 CviLux Corporation
3				DRAWN BY: Sandy	4/15-15'	TOLERANCE UNLESS OTHERWISE SPECIFIED	MATERIAL:	
2				ENGINEER: Sun	4/15-15'	.X ± 0.30±.012 X' ± 1'	CUSTOMER: TCL0013	DRAWING NO. CH0901SA PART NO. CH09042V100
1				CHECKED BY: Eisley	4/15-15'	.XX ± 0.20±.008 .X' ±		SCALE 6 / 1 SHEET 1 OF 1
SYM	NAME	DATE	REVISIONS	APPROVED BY: Eisley	4/15-15'	.XXX ± 0.10±.004 .XX' ±		