

Material :

* Base:

High Temperature Plastic UL 94V-0 Color Nature (Halogen-Free)

* Contact : Phosphor Bronze

* Fixed tab : Phosphor Bronze with Matte Tin Plated over Nickel

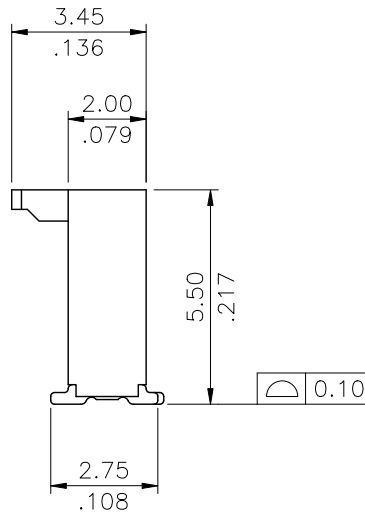
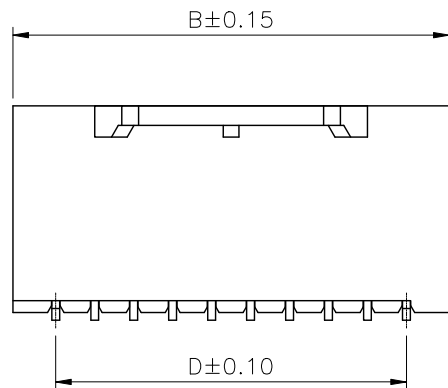
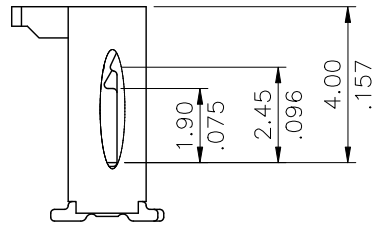
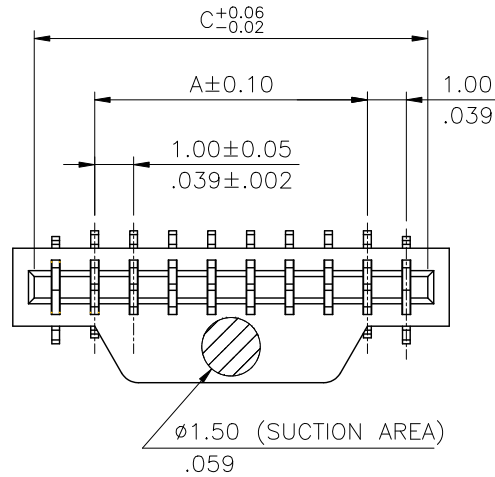

Ordering Code:

CF65 08 1 M 0 R A -10 -NH
 ① ② ③ ④ ⑤ ⑥ ⑦ ⑧ ⑨

- ① Series No.
- ② No. of Circuits:
- ③ Plating:
 - 1= 3.05 μ m(120 μ "") Min. Matte Tin Plating on Contact area and Solder tails, 1.27 μ m(50 μ "") Nickel Underplating over all
 - 2= 0.03 μ m(1.2 μ "") Min. Gold Flash Plated over 1.27 μ m(50 μ "") Nickel
- ④ Contact style: M= Top entry Type(SMT)
- ⑤ 0= Color Nature
- ⑥ Packing Options: R= Tape & Reel packing and
- ⑦ Options: A= Short Solder tail
- ⑧ -10= 1.00 Pitch
- ⑨ Other option:
 - NH= For Lead Free IR Processes and Halogen-Free

Halogen-Free

Lead Free Process

RoHS Compliant

④						DATE	UNIT: mm / inch	TITLE: 1.00mm(.039") SMT ZIF FFC/FPC CONNECTOR	 瀚荃股份有限公司 CviLux Corporation	
③					DRAWN BY: Clark	10/12-15	TOLERANCE UNLESS OTHERWISE SPECIFIED	MATERIAL:		DRAWING NO. CF6502S3
②					ENGINEER: Clark	10/12-15	.X ± 0.20/.008 .X' ± 1"	FINISH:	SCALE	5 / 1
①					CHECKED BY: David	10/12-15	.XX ± 0.15/.006 .X' ±		SHEET	1
SYM	NAME	DATE	REVISIONS	APPROVED BY: David	10/12-15	.XXX ±	.XX' ±			

Circuits	Dimension			
	A	B	C	D
5	4.00(.157)	8.20(.323)	7.08(.279)	6.00(.236)
6	5.00(.197)	9.20(.362)	8.08(.318)	7.00(.276)
7	6.00(.236)	10.20(.402)	9.08(.357)	8.00(.315)
8	7.00(.276)	11.20(.441)	10.08(.397)	9.00(.354)
9	8.00(.315)	12.20(.480)	11.08(.436)	10.00(.394)
10	9.00(.354)	13.20(.520)	12.08(.476)	11.00(.433)
11	10.00(.394)	14.20(.559)	13.08(.515)	12.00(.472)
12	11.00(.433)	15.20(.598)	14.08(.554)	13.00(.512)
13	12.00(.472)	16.20(.638)	15.08(.594)	14.00(.551)
14	13.00(.512)	17.20(.677)	16.08(.633)	15.00(.591)
15	14.00(.551)	18.20(.717)	17.08(.672)	16.00(.630)
16	15.00(.591)	19.20(.756)	18.08(.712)	17.00(.669)
17	16.00(.630)	20.20(.795)	19.08(.751)	18.00(.709)
18	17.00(.669)	21.20(.835)	20.08(.791)	19.00(.748)

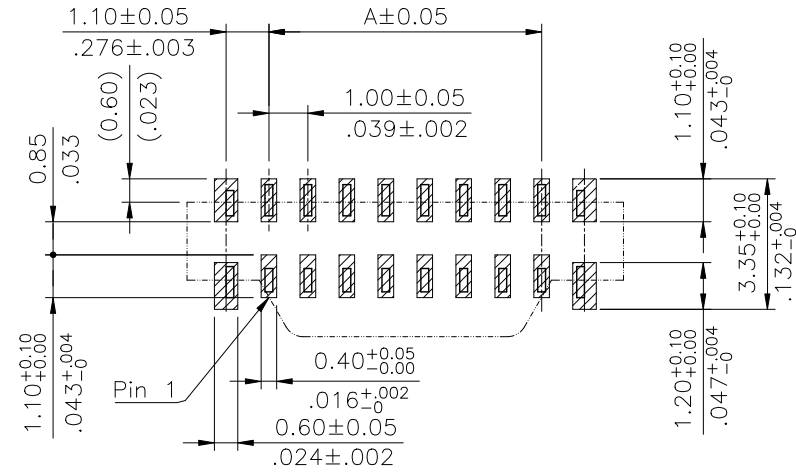

Recommended PCB Layout

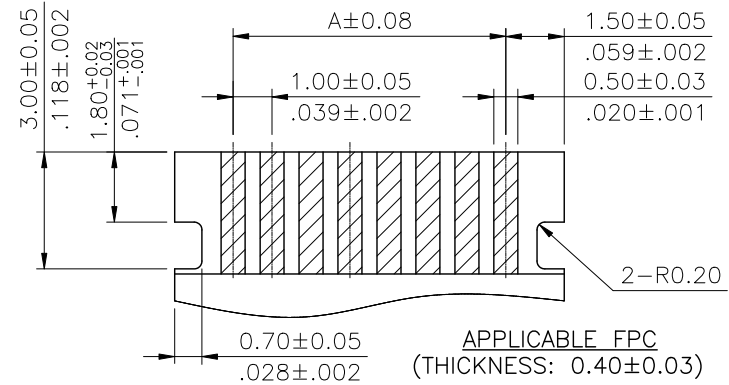

APPLICABLE FPC
(THICKNESS: 0.40±0.03)

Halogen-Free

Lead Free Process

RoHS Compliant

4					DATE	UNIT: mm / inch	TITLE: 1.00mm(.039") SMT ZIF	瀚荃股份有限公司 CviLux Corporation		
3					DATE	TOLERANCE UNLESS OTHERWISE SPECIFIED	FFC/FPC CONNECTOR			
2					DRAWN BY: Clark	.X ± 0.20/.008	.X' ± 1'	MATERIAL:	DRAWING NO. CF6502S3	PART NO. CF65***MORA-10-NH
1					ENGINEER: Clark	.XX ± 0.15/.006	.X' ±	FINISH:	SCALE 5 / 1	SHEET 2 OF 3
SYM	NAME	DATE	REVISIONS		CHECKED BY: David	.XXX ±	.XX' ±			
					APPROVED BY: David					

CVILUX CORP.
 2015.10.12
 ISSUED

