

Material :

- \* Body: High temperature plastic UL 94V-0, Color Nature
- \* Cover: High temperature plastic UL 94V-0, Color Black
- \* Contact: Phosphor Bronze
- \* Fixed tab: Brass with 2.50μm(100μ") Min. Matte Tin Plated over 1.27μm(50μ") Min. Nickel

### Ordering Code

CF50 \*\* \* D 0 \* 0 -05 -NH  
 ① ② ③ ④ ⑤ ⑥ ⑦ ⑧

① Series No.

② No. of Circuits:

③ Plating code:

- 1= 2.50μm(100μ") Min. Matte Tin Plating on Contact area and Solder tails, 1.27μm(50μ") Nickel Underplating over all
- F= 0.02μm(0.8μ") Min. Gold Flash Plating on Contact area and Solder tails, 1.27μm(50μ") Nickel Underplating over all

④ Contact style: D= Downside contact

⑤ 0= Color Nature

⑥ Packing: R0= Tape & Reel(3Kpcs/Reel) ,Without Mylar  
 R1= Tape & Reel(3Kpcs/Reel) ,With Mylar

⑦ -05= 0.5 Pitch

⑧ -NH= For Lead Free IR Processed and Halogen Free

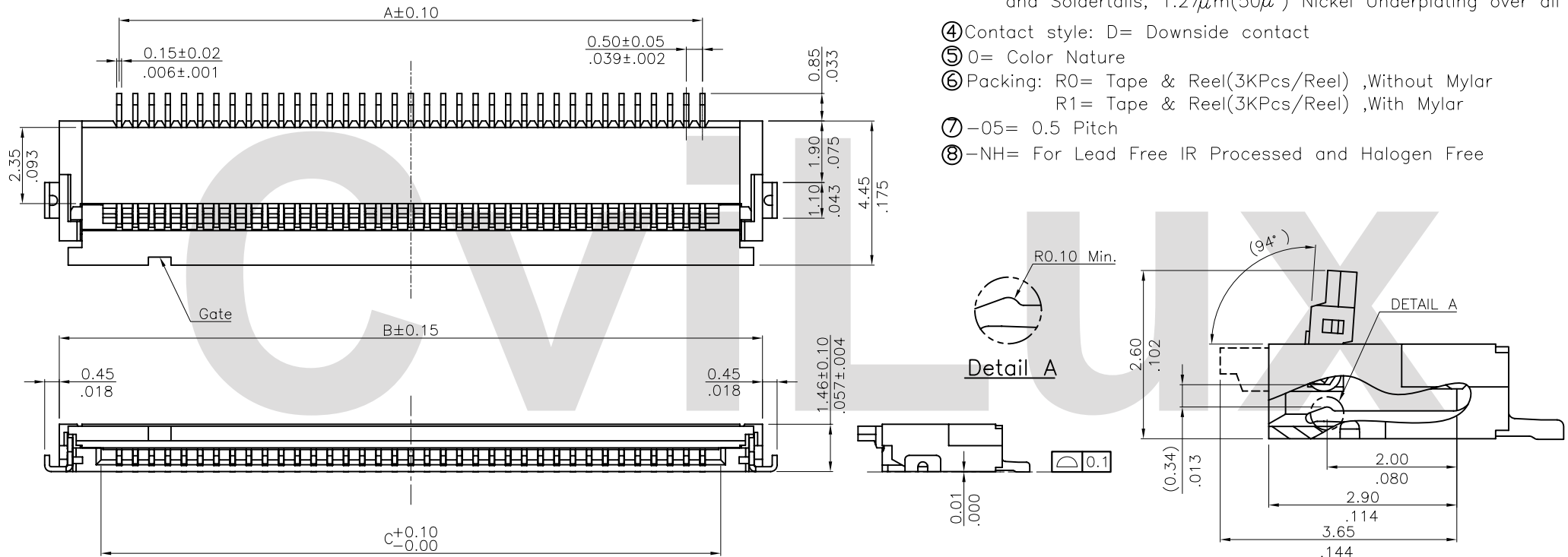

CVILUX CORP  
 2014.11.14  
 ISSUED

Halogen-Free    Lead Free Process    RoHS compliant

④					DATE	UNIT: mm / inch	TITLE: 0.50mm(.020") ZIF FFC/FPC ONE-TOUCH CONNECTOR	 瀚荃股份有限公司 CviLux Corporation
③	Clarie	10/6-14'	ECRT214034/ECNT214065	DRAWN BY: Claire	11/10-14"	TOLERANCE UNLESS OTHERWISE SPECIFIED	MATERIAL:	
②	Clarie	8/12-14'	ECRT214027/ECNT214043	ENGINEER: Francis	11/10-14"	.X ± 0.20/.008    .X' ± 1'	FINISH:	DRAWING NO. CF5002SB    PART NO. CF50***D0**-05-NH
①	Clarie	11/11-13'	ECRT213001/ECRT213004 ECNT213013	CHECKED BY: Jerry	11/10-14"	.XX ± 0.15/.006    .X' ±		SCALE 8 / 1    SHEET 1 OF 3
SYM	NAME	DATE	REVISIONS	APPROVED BY: Scott	11/10-14"	.XXX ±    .XX' ±		

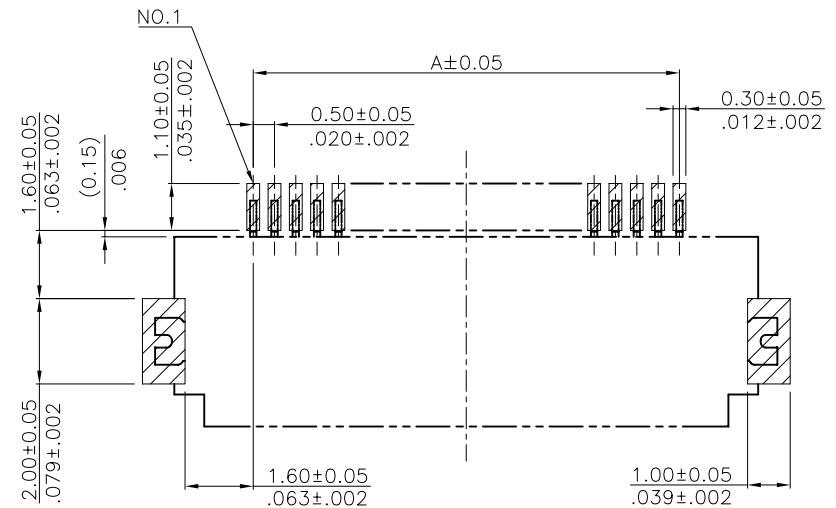
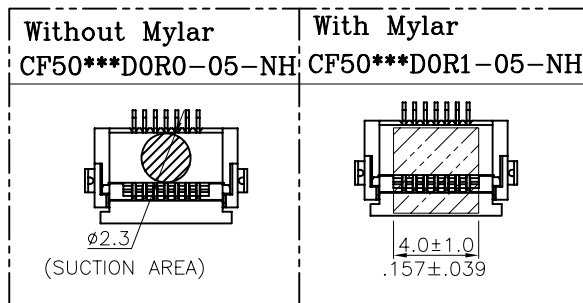

Recommended PCB Layout

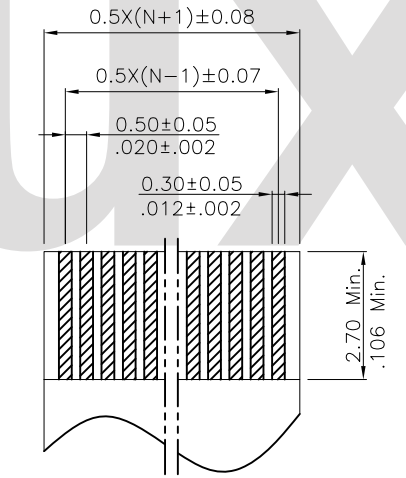

(THICKNESS: 0.3±0.03)  
APPLICABLE FFC/FPC DIM.

Halogen-Free  
Lead Free Process  
RoHS Compliant

Circuits (N)	Dimension		
	A	B	C
4	1.50 (.059)	5.20 (.205)	2.62 (.103)
5	2.00 (.079)	5.70 (.225)	3.12 (.123)
6	2.50 (.099)	6.20 (.244)	3.62 (.143)
7	3.00 (.118)	6.70 (.264)	4.12 (.162)
8	3.50 (.138)	7.20 (.284)	4.62 (.182)
9	4.00 (.158)	7.70 (.303)	5.12 (.202)
10	4.50 (.177)	8.20 (.323)	5.62 (.221)
11	5.00 (.197)	8.70 (.343)	6.12 (.241)
12	5.50 (.217)	9.20 (.362)	6.62 (.261)
13	6.00 (.236)	9.70 (.382)	7.12 (.281)
14	6.50 (.256)	10.20 (.402)	7.62 (.300)
15	7.00 (.276)	10.70 (.422)	8.12 (.320)
16	7.50 (.296)	11.20 (.441)	8.62 (.340)
17	8.00 (.315)	11.70 (.461)	9.12 (.359)
18	8.50 (.335)	12.20 (.481)	9.62 (.379)
19	9.00 (.355)	12.70 (.500)	10.12 (.399)
20	9.50 (.374)	13.20 (.520)	10.62 (.418)
21	10.00 (.394)	13.70 (.540)	11.12 (.438)
22	10.50 (.414)	14.20 (.559)	11.62 (.458)
23	11.00 (.433)	14.70 (.579)	12.12 (.478)
24	11.50 (.453)	15.20 (.599)	12.62 (.497)
25	12.00 (.473)	15.70 (.619)	13.12 (.517)
26	12.50 (.493)	16.20 (.638)	13.62 (.537)
27	13.00 (.512)	16.70 (.658)	14.12 (.556)
28	13.50 (.532)	17.20 (.678)	14.62 (.576)
29	14.00 (.552)	17.70 (.697)	15.12 (.596)
30	14.50 (.571)	18.20 (.717)	15.62 (.615)
31	15.00 (.591)	18.70 (.737)	16.12 (.635)
32	15.50 (.611)	19.20 (.756)	16.62 (.655)

Circuits (N)	Dimension		
	A	B	C
33	16.00 (.630)	19.70 (.776)	17.12 (.675)
34	16.50 (.650)	20.20 (.796)	17.62 (.694)
35	17.00 (.670)	20.70 (.816)	18.12 (.714)
36	17.50 (.690)	21.20 (.835)	18.62 (.734)
37	18.00 (.709)	21.70 (.855)	19.12 (.753)
38	18.50 (.729)	22.20 (.875)	19.62 (.773)
39	19.00 (.749)	22.70 (.894)	20.12 (.793)
40	19.50 (.768)	23.20 (.914)	20.62 (.812)
41	20.00 (.788)	23.70 (.934)	21.12 (.832)
42	20.50 (.808)	24.20 (.953)	21.62 (.852)
43	21.00 (.827)	24.70 (.973)	22.12 (.872)
44	21.50 (.847)	25.20 (.993)	22.62 (.891)
45	22.00 (.867)	25.70 (1.013)	23.12 (.911)
46	22.50 (.887)	26.20 (1.032)	23.62 (.931)
47	23.00 (.906)	26.70 (1.052)	24.12 (.950)
48	23.50 (.926)	27.20 (1.072)	24.62 (.970)
49	24.00 (.946)	27.70 (1.091)	25.12 (.990)
50	24.50 (.965)	28.20 (1.111)	25.62 (1.009)
51	25.00 (.985)	28.70 (1.131)	26.12 (1.029)
52	25.50 (1.005)	29.20 (1.150)	26.62 (1.049)
53	26.00 (1.024)	29.70 (1.170)	27.12 (1.069)
54	26.50 (1.044)	30.20 (1.190)	27.62 (1.088)
55	27.00 (1.064)	30.70 (1.210)	28.12 (1.108)
56	27.50 (1.084)	31.20 (1.229)	28.62 (1.128)
57	28.00 (1.103)	31.70 (1.249)	29.12 (1.147)
58	28.50 (1.123)	32.20 (1.269)	29.62 (1.167)
59	29.00 (1.143)	32.70 (1.288)	30.12 (1.187)
60	29.50 (1.162)	33.20 (1.308)	30.62 (1.206)
61	30.00 (1.182)	33.70 (1.328)	31.12 (1.226)

4					DATE	UNIT: mm / inch	TITLE: 0.50mm(.020") ZIF FFC/FPC ONE-TOUCH CONNECTOR	瀚荃股份有限公司 CviLux Corporation	
3	Clarie	10/6-14'	ECRT214034/ECNT214065	DRAWN BY: Claire	11/10-14"	TOLERANCE UNLESS OTHERWISE SPECIFIED	MATERIAL:		
2	Clarie	8/12-14'	ECRT214027/ECNT214043	ENGINEER: Francis	11/10-14"	.X ± 0.20/.008 X' ± 1'	FINISH:	DRAWING NO. CF5002SB	PART NO. CF50***D0**-05-NH
1	Clarie	11/11-13'	ECRT213001/ECNT213004 ECNT213013	CHECKED BY: Jerry	11/10-14"	.XX ± 0.15/.006 X' ±		SCALE 8 / 1	SHEET 2 OF 3
SYM	NAME	DATE	REVISIONS	APPROVED BY: Scott	11/10-14"	.XXX ± .XX ±			

2014.11.14  
ISSUED

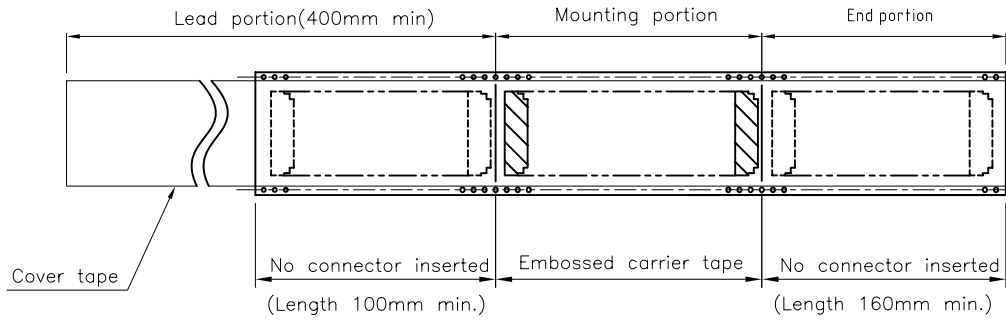

Notes:

1. 10 sprocket hole pitch cumulative tolerance  $\pm 0.2$
2. Material: Polystyrene.
3. Quantity: 3000 Pcs/Reel
4. All dimensions meet EIA-481-B requirements.

Circuits	Dimension		Packing (Reel/Caton)
	W	F	
4-7	16.0(.630)	7.50(.295)	11
8-24	24.0(.945)	11.50(.453)	9
25-32	32.0(1.260)	14.20(.559)	7
33-56	44.0(1.732)	20.20(.795)	5
57-63	56.0(2.205)	26.20(1.031)	4

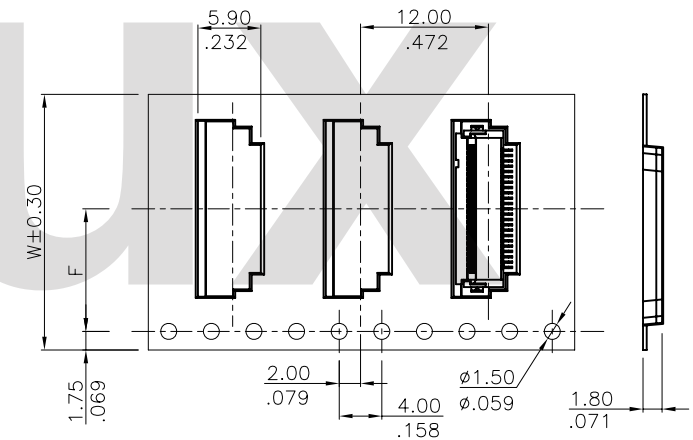
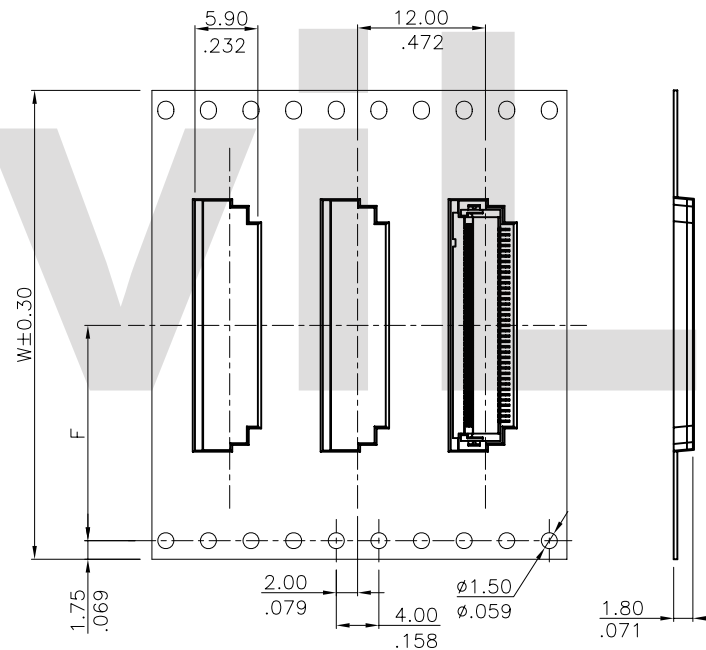
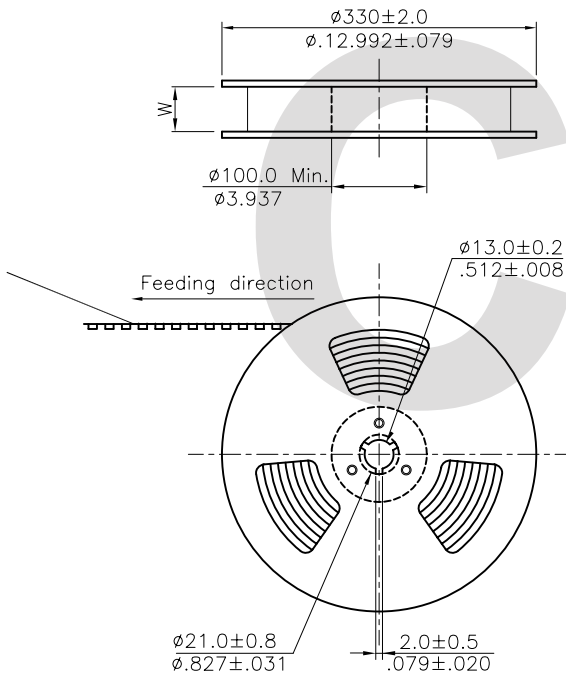

WIDTH : 16, 24 mm Carrier

WIDTH : 32,44,56 mm Carrier

RoHS Compliant

CVILUX CORP  
2014.11.14  
ISSUED

4	3	2	1	SYM	NAME	DATE	REVISIONS	APPROVED BY:	SCOTT	11/10-14"	UNIT: mm / inch	TOLERANCE UNLESS OTHERWISE SPECIFIED	.X $\pm 0.20/.008$	X' $\pm 1'$	.XX $\pm 0.15/.006$	.X' $\pm$	.XXX $\pm$	.XX' $\pm$	
	Clarie	0/6-14'	ECRT214034/ECNT214065					DRAWN BY:	Claire	11/10-14"									
	Clarie	8/12-14'	ECRT214027/ECNT214043					ENGINEER:	Francis	11/10-14"									
	Clarie	11/11-13'	ECRT213001/ECRT213004 ECNT213013					CHECKED BY:	Jerry	11/10-14"									
								APPROVED BY:	Scott	11/10-14"									

TITLE: 0.50mm(.020") ZIF FFC/FPC ONE-TOUCH CONNECTOR  
MATERIAL:  
FINISH:

瀚荃股份有限公司  
CviLux Corporation

DRAWING NO. CF5002SB PART NO. CF50\*\*\*D0\*\*-05-NH  
SCALE 8 / 1 SHEET 3 OF 3