

| | | |
|----------------------|----------------------------|--------------------|
| ENGINEERING DEPT. | CRIMP SPECIFICATION | SPEC. No.:SCCP009C |
| | For CP04T02***0 TERMINAL | PAGE: 1 / 1 |

1. Crimp height and width of crimped core should be set as required. (crimped height and width of wire barrel)
2. Crimp width of crimped sheath shall be adjusted according to the final out side diameter and the kind of electric wire, to the extent that sheathed wire won't be easily taken off from contact nor too much crimped. (crimped width of insulation barrel)

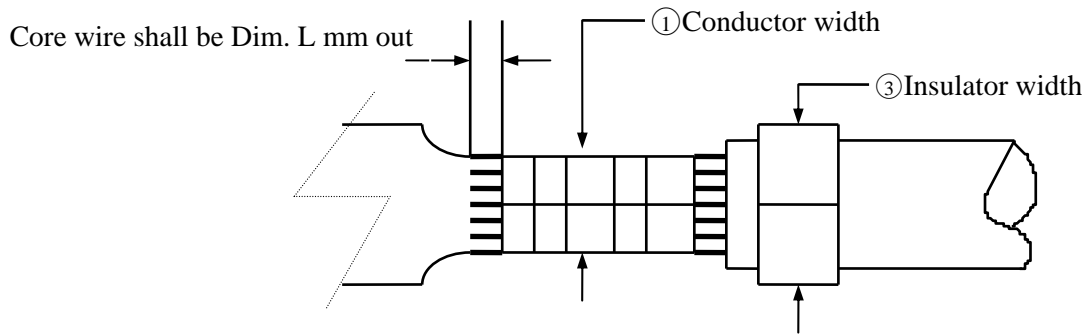

Naked part of sheathed wire must be located in the vicinity of center

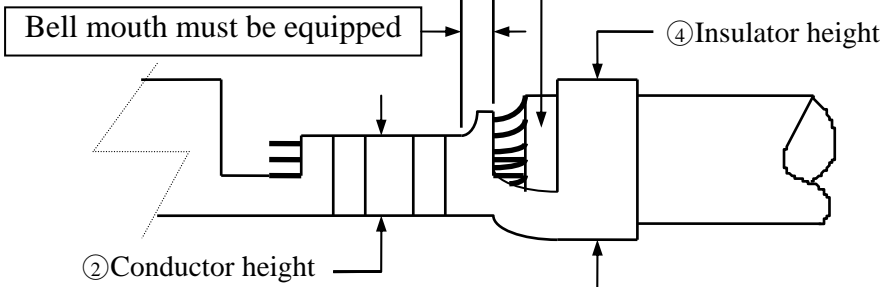

Subject : UL 3239 or equivalent type electric wire

| AWG # | Conductor mm ² | Insulator Diameter | Applicator | Core crimp length | Dim. L |
|-----------|---------------------------|--------------------|-------------|-------------------|--------------|
| #24 - #28 | 0.216 - 0.079 | 1.60 - 1.37mm | A01CP04T021 | 2.3 - 2.5 mm | 0.2 - 0.4 mm |

| Wire Gage (AWG #) | Conductor Crimp Area | | Insulator Crimp Area | | Terminal Tensile Strength |
|----------------------|----------------------|-------------|----------------------|------------|------------------------------|
| | Width (1) | Height (2) | Width (3) | Height (4) | |
| #24 | 1.20 - 1.40 | 0.83 - 0.89 | 1.50 - 1.80 | --- | 3.0 Kgf |
| #26 | | 0.80 - 0.86 | | --- | 2.0 Kgf |
| #28 | | 0.77 - 0.83 | | --- | 1.3 Kgf |

| | | | |
|-----------|------------|----------|--------|
| DATE | REVISIONS | SPEC BY: | Ken |
| 08/04-16' | ECNT116169 | CHKD BY: | Sun |
| | | APPR BY: | Eisley |

