

CVS5 Series 0.50mm(.020") M/H=4.00 LVDS Socket for NB

- Mating Height: 4.0mm
- Mate with CVS4 Plug
- Product application: NB, LCD
- Insulation: High temperature plastic+Glass Fiber Filled Polyester, UL 94V-0, Color Black
- Cap: High temperature plastic, Color Black
- Shell: Stainless Steel
- Contact: Copper Alloy

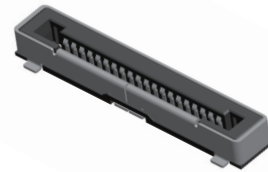

CVS

RoHS Compliant

P/N CVS520*M1R0-NH

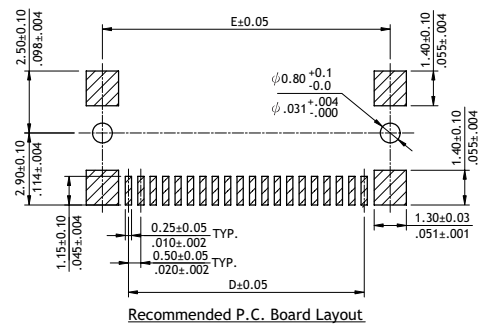
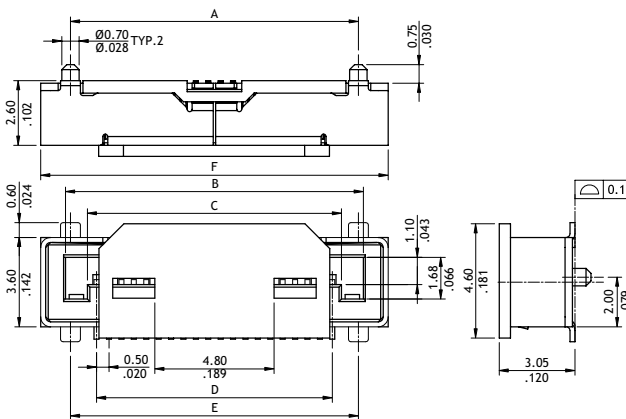

Circuits	Dimension					
	A	B	C	D	E	F
20	11.60(.457)	12.00(.472)	10.24(.403)	9.50(.374)	11.60(.457)	14.0(.551)

P/N CVS5***M1RA-NH

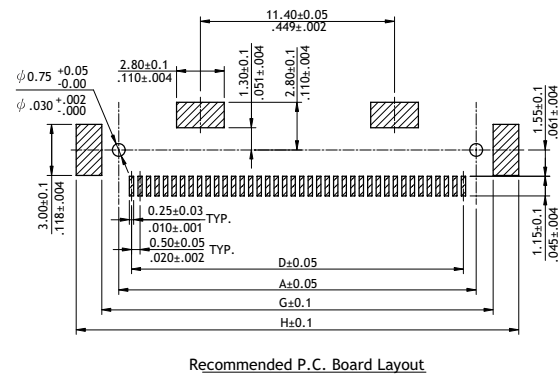
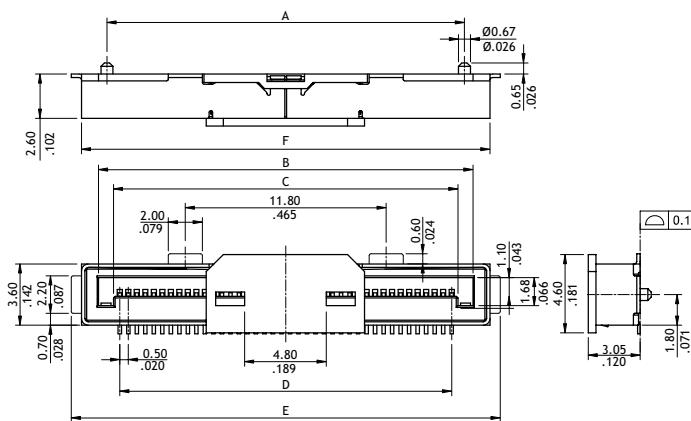

Circuits	Dimension							
	A	B	C	D	E	F	G	H
30	16.00(.630)	17.00(.670)	15.24(.600)	14.50(.571)	20.2(.795)	19.0(.748)	18.0(.709)	21.0(.827)
40	21.00(.827)	22.00(.866)	20.24(.797)	19.50(.758)	25.2(.992)	24.0(.945)	23.0(.906)	26.0(1.024)

Ordering Code

1 CVS **2** 5 **3** 4 **4** 0 **5** 2 **6** M **7** 1 **8** RA - **9** NH

- 1** Series No.
- 2** No. of Circuits: 20, 30, 40
- 3** Plating code:
2 = Gold flash over Nickel
E = Selective 10μ"Min. Gold plated on contact area
*Optional plating available but MOQ requested
- 4** M = SMT Type
- 5** Color: 1 = Black
- 6** Packing Options: R0 = Tape & Reel 2000PCS (20pin)
RA = Tape & Reel 1250PCS (30,40pin)
* Special options consult manufacturer
- 7** -NH = For Lead Free IR process and Halogen-Free

LVDS CONNECTOR