

CF08 Series 1.00mm(.039")H=2.60/3.55 SMT LIF & SMT LIF Vertical FFC/FPC

- Tin over copper alloy dual contacts
- Insulator: High temperature plastic UL 94V-0
- With metal fixed tabs to secure connector in place

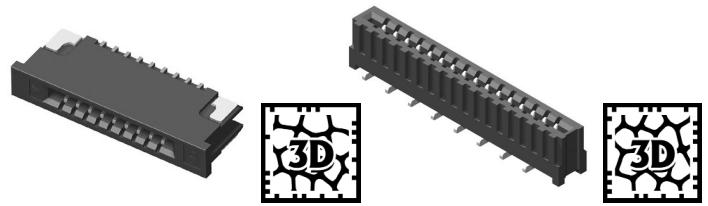

A = 1.0 * No. of Spaces
 B = A + 8.0
 C = A + 2.1

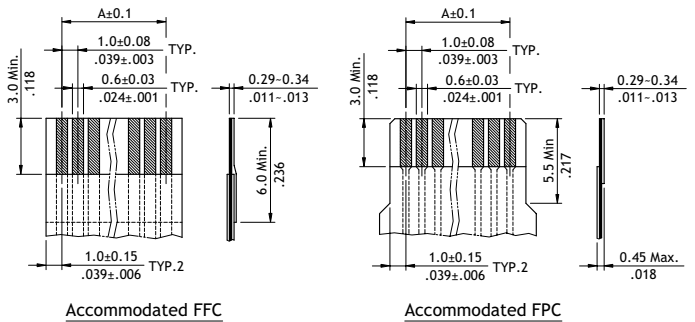
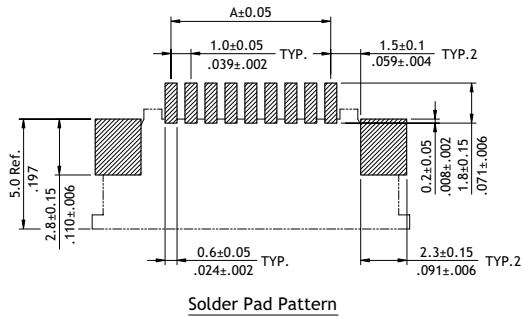
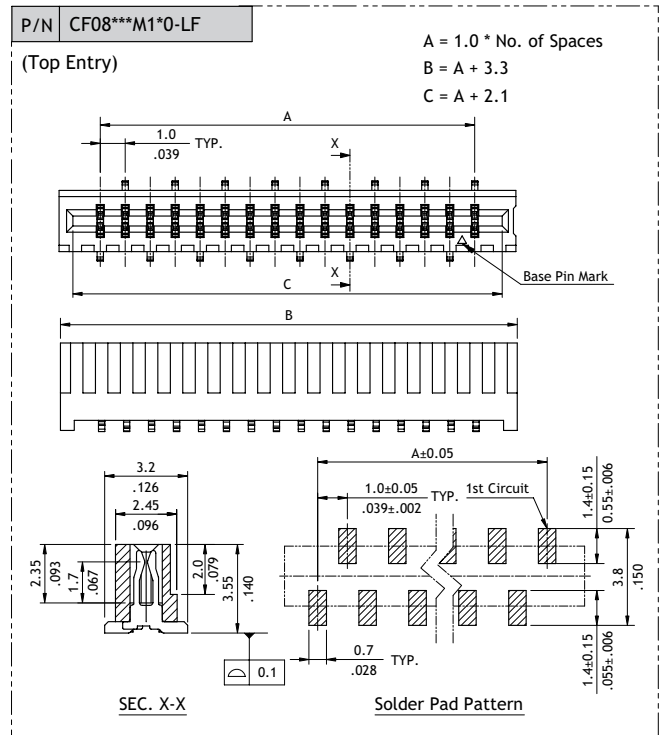
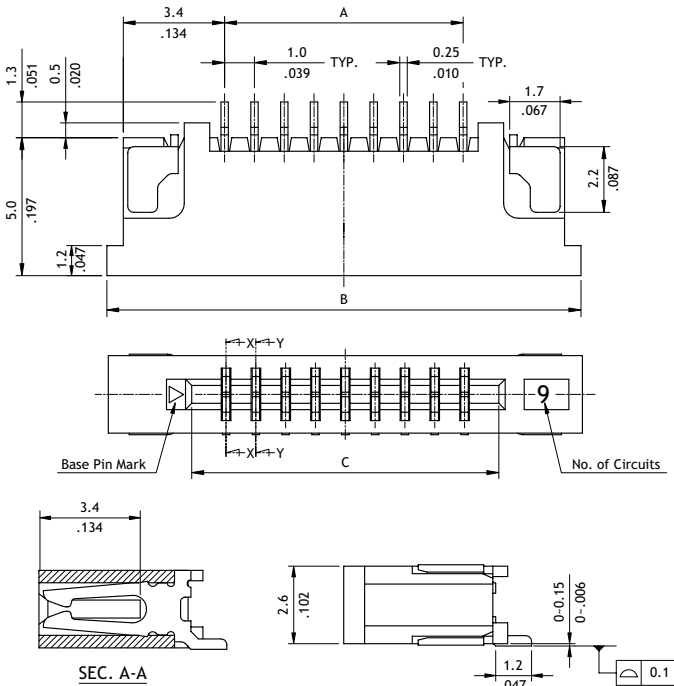

Ordering Code

① CF08 ② 32 ③ 1 ④ H ⑤ 2 ⑥ R ⑦ 0 - ⑧ NH

- ① Series No.
- ② No. of Circuits: 04 to 32
- ③ Plating Code:
1 = Matte Tin over Nickel
- ④ Contact Style:
H = SMT Side Entry
M = SMT Top Entry
- ⑤ Color: 1 = Black (Top Entry)
2 = Brown (Side Entry)
- ⑥ Packing: R = Tape & Reel
T = Tube
- ⑦ Other Options: 0 = Standard
*Special options consult manufacturer
- ⑧ -LF = For Lead Free soldering process (Top Entry)
-NH = For Lead Free soldering process and Halogen-Free (Side Entry)