

CF20 Series 1.00mm(.039") H=2.00 SMT ZIF FFC/FPC Connectors

- ⊙ Insulator: High temperature plastic UL 94V-0, Color Nature
- ⊙ Slider: High temperature plastic UL 94V-0, Color Black
- ⊙ With metal fixed tabs to secure connector in place

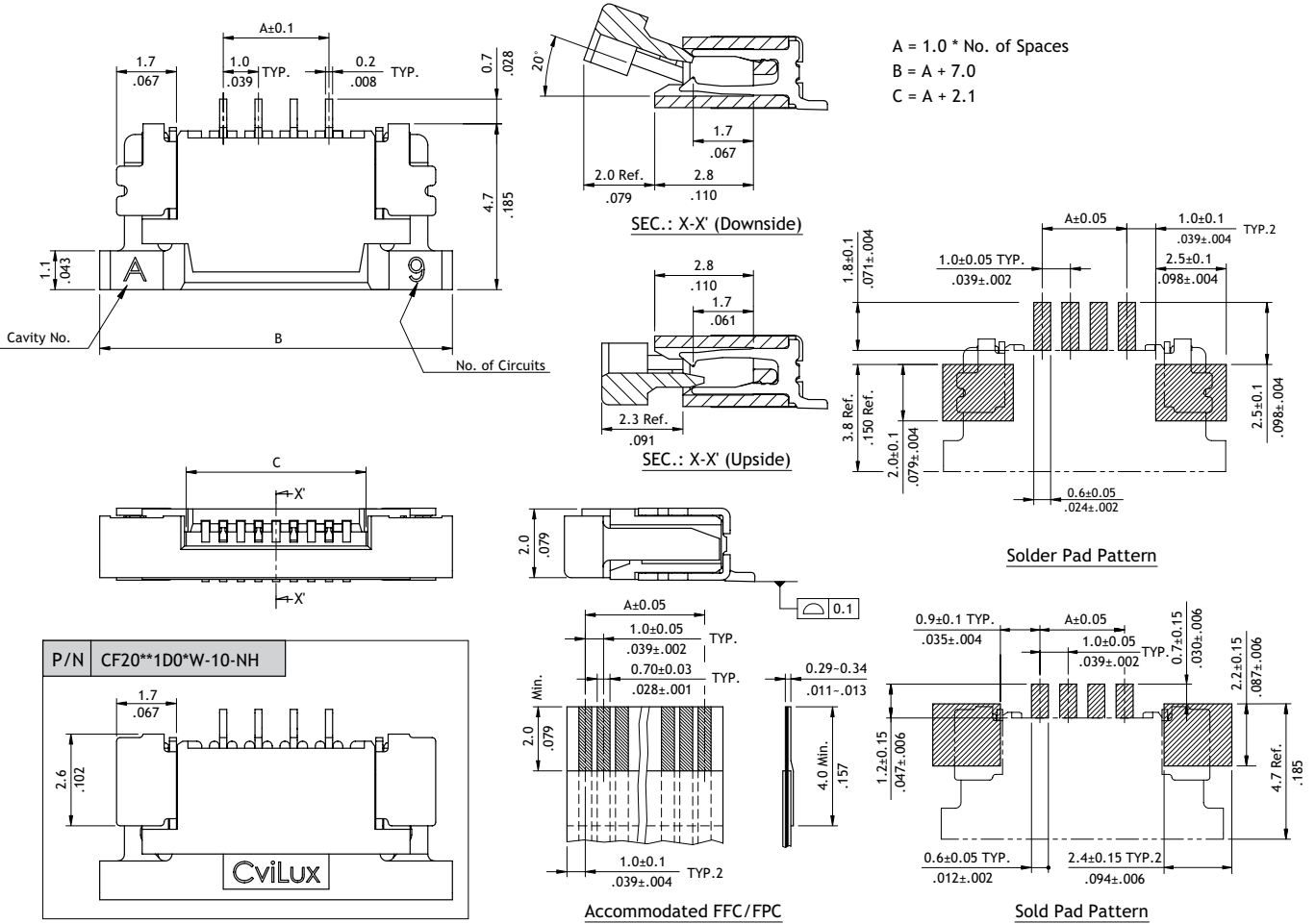
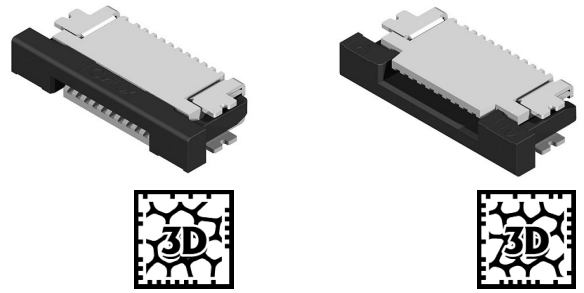

Ordering Code

① ② ③ ④ ⑤ ⑥ ⑦ ⑧ ⑨
CF 20 27 1 U 0 R 0 - 10 - NH

- ①** Series No.
- ②** No. of Circuits: 02 to 27
- ③** Plating Code:
1 = Matte Tin over Nickel
2 = Gold flash over Nickel
- ④** Contact Style:
U = Upside Contact
D = Downside Contact
- ⑤** Color: 0 = Nature
- ⑥** Packing Options:
R = Tape & Reel
T = Tube
- ⑦** Other Options: 0 = Standard
W = Wide Tabs
*Special options consult manufacturer
- ⑧** Pitch: 10 = 1.00 mm
- ⑨** -LF = For Lead Free soldering process
-NH = For Lead Free soldering process and Halogen-Free