

CD52 Series Crimp Clip Terminal

- Mate with Cvilux CD52 D-Sub
- Low insertion force

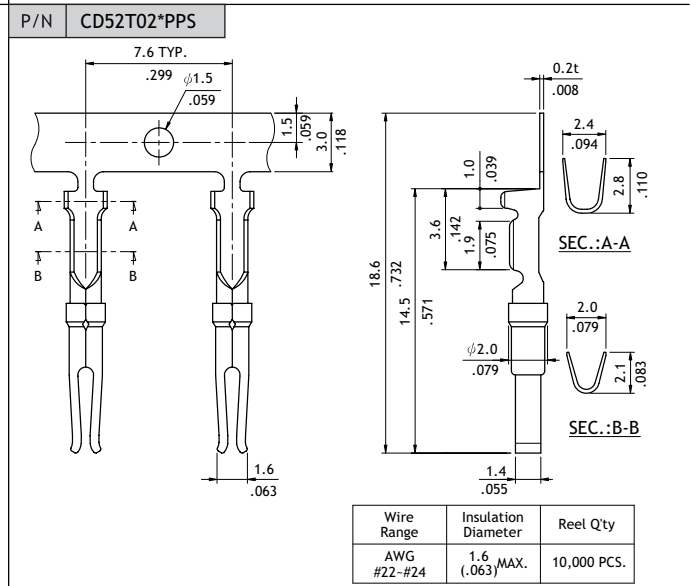
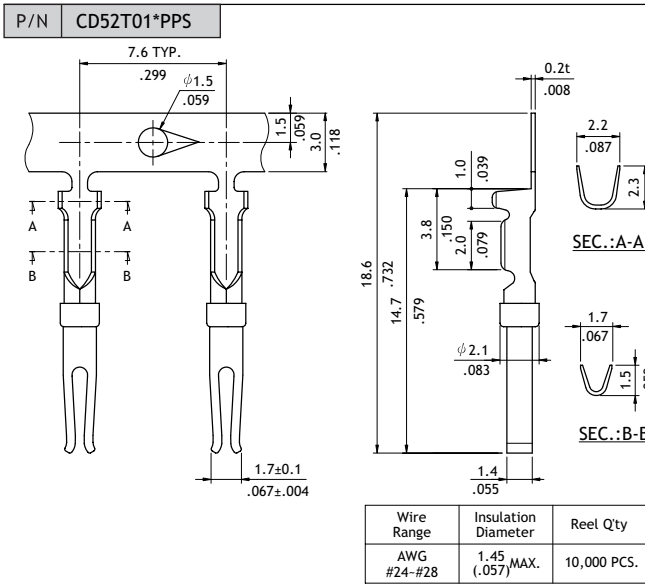
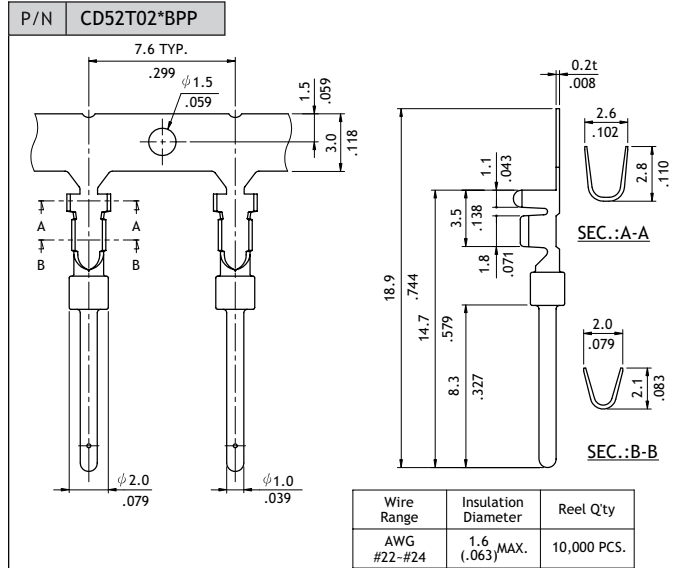
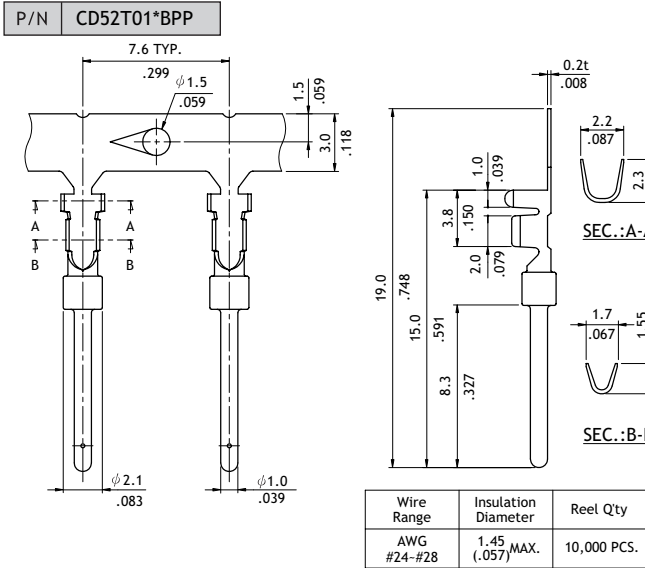
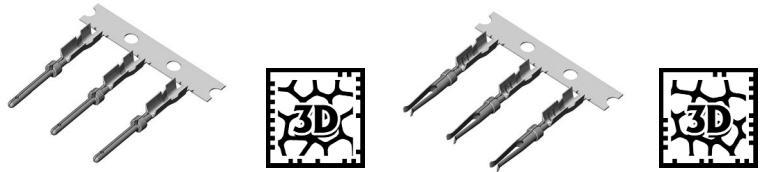

Ordering Code

1 **CD52**
2 **T01**
3 **A**
4 **B**
5 **P**
6 **P**

- 1** Series No.
- 2** No. of Circuits:
T01 = for AWG #24 ~ #28
T02 = for AWG #22 ~ #24
- 3** Plating Code:
A = Selective Gold flash over Nickel
*Optional plating available but MOQ requested
- 4** Material: B = Brass (Plug)
P = Phosphor Bronze (Receptacle)
- 5** Plating method:
P = Post-plating
- 6** Type: P = Plug Terminal
S = Receptacle Terminal