

Ordering Code

CF17 ** 1 U 0 RA -NH
 ① ② ③ ④ ⑤ ⑥ ⑦

① Series No.

② No. of Circuits

⚠ ③ Plating code:

1= 3.05um(120u") Min. Matte Tin
 over 0.76um(30u") Nickel

2= Gold Flash plated over
 1.27um(50u") Nickel

④ Contact style: U= Upside contact

⑤ Color: 0= Nature

⑥ Other option: RA= Tape & Reel
 TA= Tube Packing

⑦ Other option:

NH= For Lead Free IR Processes
 and Halogen-Free

Material :

* Body : High temperature plastic UL 94V-0
 Color Nature

* Slider : High temperature plastic UL 94V-0
 Color Black

* Contact : Copper alloy with Matte Tin
 or Gold plated

* Fixed tab : Copper alloy with Matte Tin plated

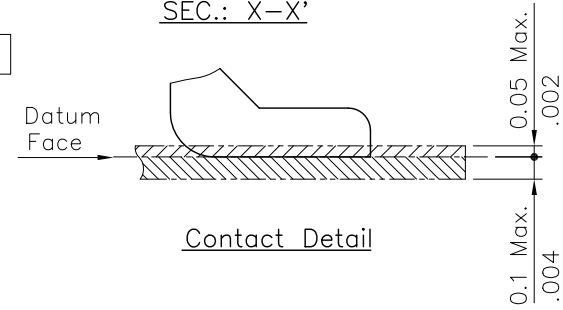
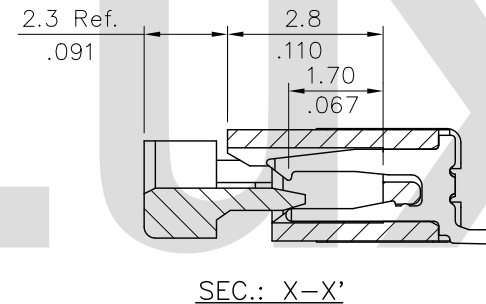
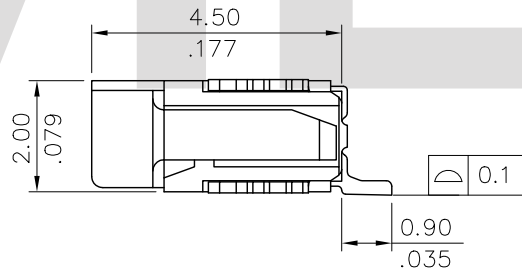
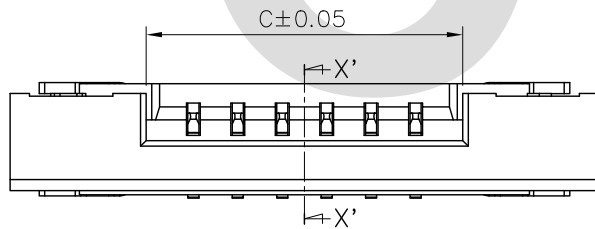
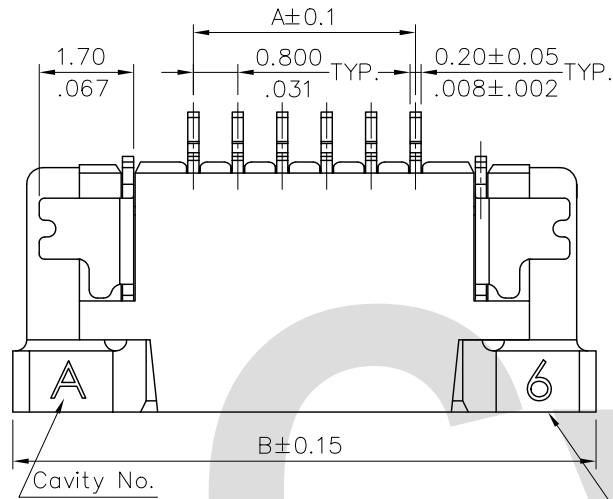

Halogen-Free
 Lead Free Process
 RoHS Compliant

④						DATE	UNIT: mm / inch	TITLE: 0.80mm(.031") ZIF FFC/FPC UPSIDE CONTACT SURFACE MOUNT CONNECTOR	 瀚荃股份有限公司 CviLux Corporation
③						8/30-12'	TOLERANCE UNLESS OTHERWISE SPECIFIED	MATERIAL:	
②	Enya	8/30-12'	ECR12043-2/ECN12209-0	DRAWN BY: Enya	ENGINEER: Eisley	9/03-12'	.X ± 0.15/.006 X' ± 1'	FINISH:	
①	Eisley	6/21-12'	ECN12112-0	CHECKED BY: Eisley		9/03-12'	.XX ± 0.10/.004 .X' ±	DRAWING NO. CF1701SC PART NO. CF17**1U0RA-NH CF17**2U0RA-NH	
SYM	NAME	DATE	REVISIONS	APPROVED BY: David		9/03-12'	.XXX ± 0.05/.002 .XX' ±	SCALE 7 / 1 SHEET 1 OF 3	

CIVILUX CORP
 2012.09.14
 ISSUED

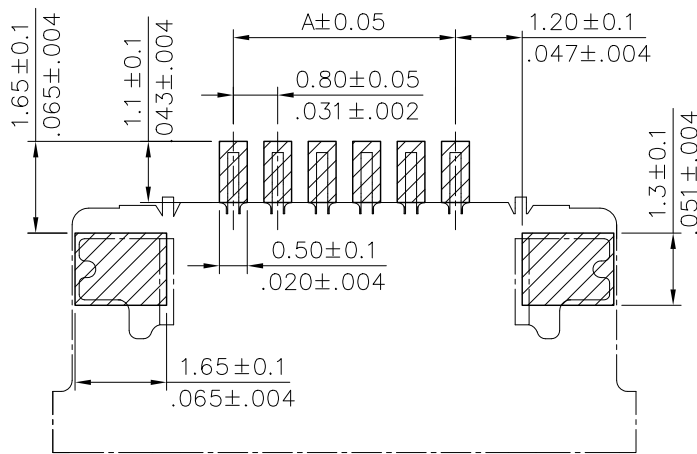

Sold Pad Pattern

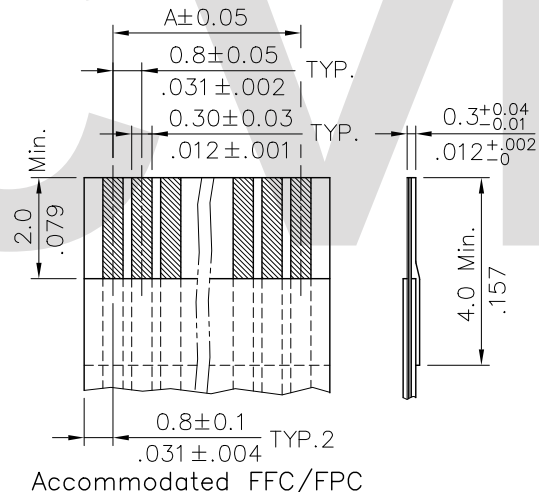

Accommodated FFC/FPC

Circuits	Dimension		
	A	B	C
4	2.40(.094)	9.00(.354)	4.10(.161)
5	3.20(.126)	9.80(.386)	4.90(.193)
6	4.00(.157)	10.60(.417)	5.70(.224)
7	4.80(.189)	11.40(.449)	6.50(.256)
8	5.60(.220)	12.20(.480)	7.30(.287)
9	6.40(.252)	13.00(.512)	8.10(.319)
10	7.20(.283)	13.80(.543)	8.90(.350)
11	8.00(.315)	14.60(.575)	9.70(.382)
12	8.80(.346)	15.40(.606)	10.50(.413)
13	9.60(.378)	16.20(.638)	11.30(.445)
14	10.40(.409)	17.00(.669)	12.10(.476)
15	11.20(.441)	17.80(.701)	12.90(.508)
16	12.00(.472)	18.60(.732)	13.70(.539)
17	12.80(.504)	19.40(.764)	14.50(.571)
18	13.60(.535)	20.20(.795)	15.30(.602)
19	14.40(.567)	21.00(.827)	16.10(.634)
20	15.20(.598)	21.80(.858)	16.90(.665)
21	16.00(.630)	22.60(.890)	17.70(.697)
22	16.80(.661)	23.40(.921)	18.50(.728)
23	17.60(.693)	24.20(.953)	19.30(.760)
24	18.40(.724)	25.00(.984)	20.10(.791)
25	19.20(.756)	25.80(1.016)	20.90(.823)
26	20.00(.787)	26.60(1.047)	21.70(.854)
27	20.80(.819)	27.40(1.079)	22.50(.886)
28	21.60(.850)	28.20(1.110)	23.30(.917)
29	22.40(.882)	29.00(1.142)	24.10(.949)
30	23.20(.913)	29.80(1.173)	24.90(.980)
31	24.00(.945)	30.60(1.205)	25.70(1.012)
32	24.80(.976)	31.40(1.236)	26.50(1.043)
33	25.60(1.008)	32.20(1.286)	27.30(1.075)
34	26.40(1.039)	33.00(1.299)	28.10(1.106)

Halogen-Free
Lead Free Process
RoHS Compliant

4																			
3																			
2	Enya	8/30-12'	ECR12043-2/ECN12209-0		DRAWN BY:	Enya	8/30-12'	UNIT: mm / inch TOLERANCE UNLESS OTHERWISE SPECIFIED .X ± 0.15/.006 X' ± 1' .XX ± 0.10/.004 .X' ± .XXX ± 0.05/.002 .XX' ±	TITLE: 0.80mm(.031") ZIF FFC/FPC UPSIDE CONTACT SURFACE MOUNT CONNECTOR MATERIAL: FINISH:	瀚荃股份有限公司 CviLux Corporation	DRAWING NO.	CF1701SC	PART NO.	CF17**1UORA-NH CF17**2UORA-NH					
1	Eisley	6/21-12'	ECN12112-0		ENGINEER:	Eisley	9/03-12'				SCALE	7 / 1	SHEET	2 OF 3					
SYM	NAME	DATE	REVISIONS		CHECKED BY:	Eisley	9/03-12'				APPROVED BY:	David	9/03-12'						

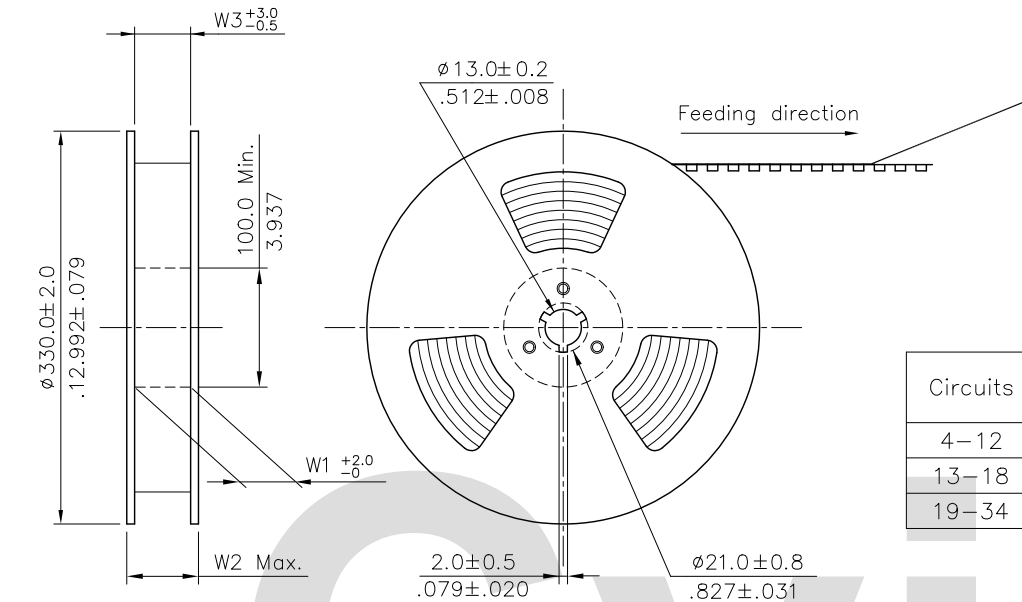

NOTE :

- * Reel Material : Corrugated Paper
- △ * Carrier Material :Black, Polystyrene alloy
- * Cover Tape Material : Polyester
- * Cover Tape Peel Strength : 0.1N – 1.3N
- * Carrier camber is within 1mm in 100mm
- * All dimensions meet EIA-481-2 & EIA-481-3 requirements.
- * Quantity : 2000 PCS/Reel

Circuits	Dimension					Packing (Reel/Caton)
	E	F	W1	W2	W3	
4-12	24.0(.945)	-	24.5(.965)	30.5(1.200)	24.5(.965)	9
13-18	32.0(1.260)	28.40(1.118)	32.5(1.280)	38.5(1.516)	32.5(1.280)	7
19-34	44.0(1.732)	40.40(1.596)	44.5(1.752)	50.5(1.988)	44.5(1.752)	5

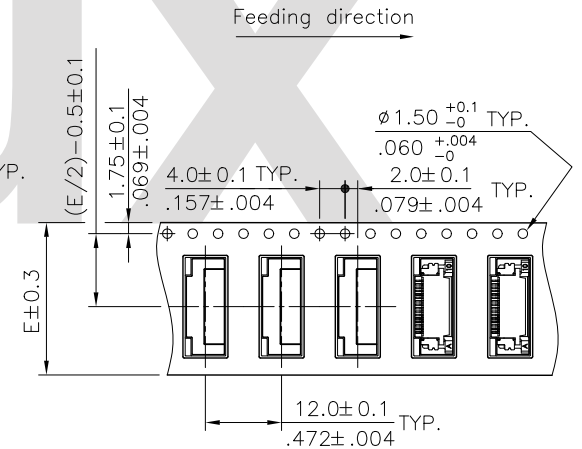
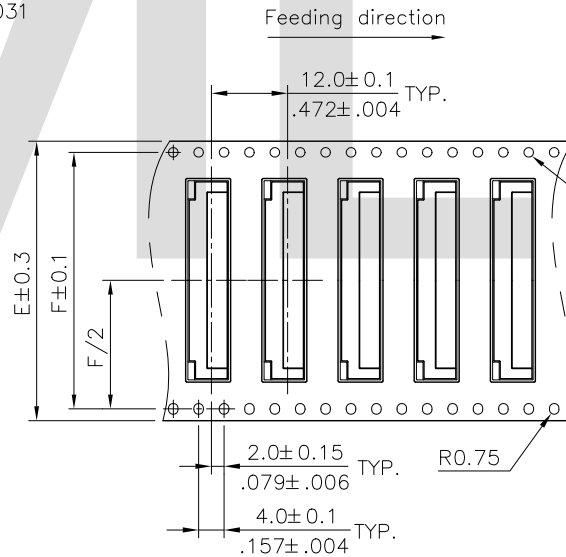
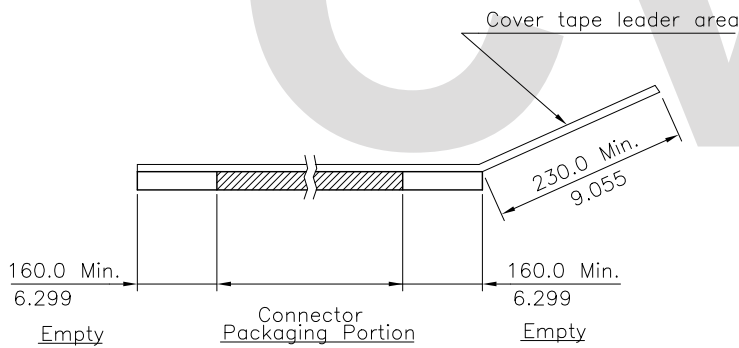

WIDTH : 24 mm Carrier

WIDTH : 32.44 mm Carrier

RoHS Compliant

4				 2012.09.14 ISSUED		DATE	UNIT: mm / inch	TITLE: 0.80mm(.031") ZIF FFC/FPC UPSIDE CONTACT SURFACE MOUNT CONNECTOR	 瀚荃股份有限公司 CviLux Corporation	
3			DRAWN BY: Enya		8/30-12'	TOLERANCE UNLESS OTHERWISE SPECIFIED	MATERIAL:	DRAWING NO. CF1701SC PART NO. CF17**1UORA-NH CF17**2UORA-NH		
2	Enya	8/30-12'	ECR12043-2/ECN12209-0		ENGINEER: Eisley	9/03-12'				.X ± X' ± ι'
1	Eisley	6/21-12'	ECN12112-0		CHECKED BY: Eisley	9/03-12'	.XX ± .X ±	FINISH:	SCALE	SHEET 3 OF 3
SYM	NAME	DATE	REVISIONS		APPROVED BY: David	9/03-12'	.XXX ± .XX ±			