

**CI21 Series 2.50mm(.098") Wire to Board Connectors DIP Headers**

- With locking slots and Pin kinked
- Mate with CI21 Housing
- Insulator: Polyamide UL 94V-0, Color Nature
- With Tin plated 0.64mm square pin

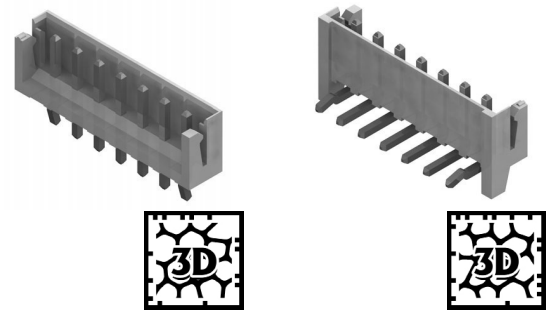

Straight

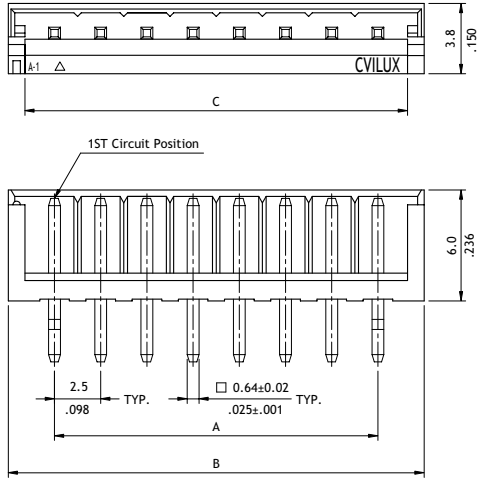

Circuits	Dimension		
	A	B	C
2	2.5(.098)	7.5(.295)	5.7(.224)
3	5.0(.197)	10.0(.394)	8.2(.323)
4	7.5(.295)	12.5(.492)	10.7(.421)
5	10.0(.394)	15.0(.591)	13.2(.520)
6	12.5(.492)	17.5(.689)	15.7(.618)
7	15.0(.591)	20.0(.787)	18.2(.717)
8	17.5(.689)	22.5(.886)	20.7(.815)
9	20.0(.787)	25.0(.984)	23.2(.913)
10	22.5(.886)	27.5(1.083)	25.7(1.012)
11	25.0(.984)	30.0(1.181)	28.2(1.110)
12	27.5(1.083)	32.5(1.280)	30.7(1.209)
13	30.0(1.181)	35.0(1.378)	33.2(1.307)
14	32.5(1.280)	37.5(1.476)	35.7(1.406)
15	35.0(1.378)	40.0(1.575)	38.2(1.504)

Right Angle

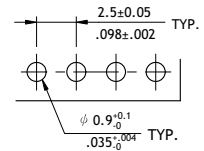
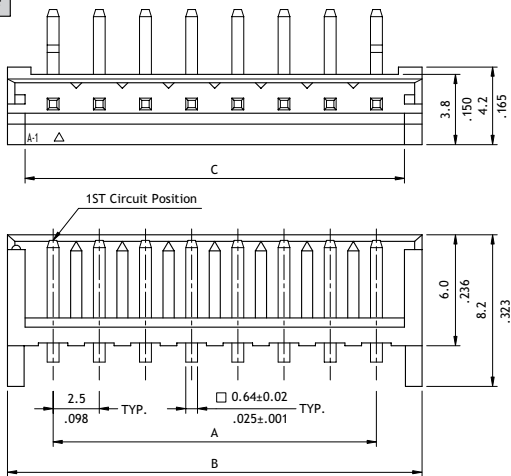

Recommended P.C. Board Layout

**Ordering Code**

**① CI 21 ② 1 5 ③ P ④ 1 ⑤ V K 0 ⑥ - ⑦ NH**

- ① Series No.
- ② No. of Circuits: 02 to 15
- ③ P = DIP Type
- ④ Plating Code: 1 = Matte Tin over Nickel
- ⑤ Type: V = Straight  
H = Right Angle
- ⑥ Other Options: 00 = Without Pin Kinked  
K0 = With Pin Kinked (Standard)
- ⑦ -LF = For Lead Free soldering process  
-NH = For Lead Free soldering process and Halogen-Free  
\*Special options consult manufacturer