

CI21 Series 2.50mm(.098") Wire to Board Connectors Housing & Terminal

- Low profile with locking ribs
- Mate with CI21 Header
- Can be used CI21 crimp clip terminal
- Insulator: Nylon 66 UL 94V-0, Color Nature
- Terminal: Tin plated Phosphor Bronze

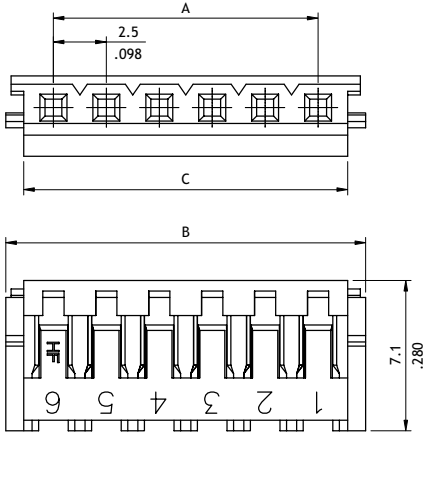

Circuits	Dimension		
	A	B	C
2	2.5(.098)	7.0(.276)	5.4(.213)
3	5.0(.197)	9.5(.374)	7.9(.311)
4	7.5(.295)	12.0(.472)	10.4(.409)
5	10.0(.394)	14.5(.571)	12.9(.508)
6	12.5(.492)	17.0(.669)	15.4(.606)
7	15.0(.591)	19.5(.768)	17.9(.705)
8	17.5(.689)	22.0(.866)	20.4(.803)
9	20.0(.787)	24.5(.965)	22.9(.902)
10	22.5(.886)	27.0(1.063)	25.4(1.000)
11	25.0(.984)	29.5(1.161)	27.9(1.098)
12	27.5(1.083)	32.0(1.260)	30.4(1.197)
13	30.0(1.181)	34.5(1.358)	32.9(1.295)
14	32.5(1.280)	37.0(1.457)	35.4(1.394)
15	35.0(1.378)	39.5(1.555)	37.9(1.492)

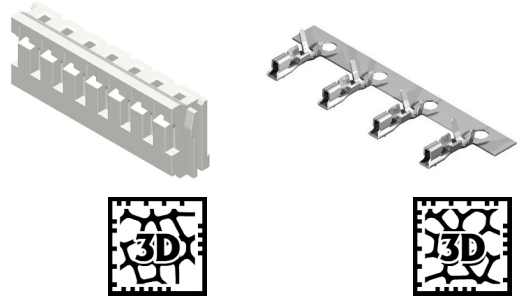
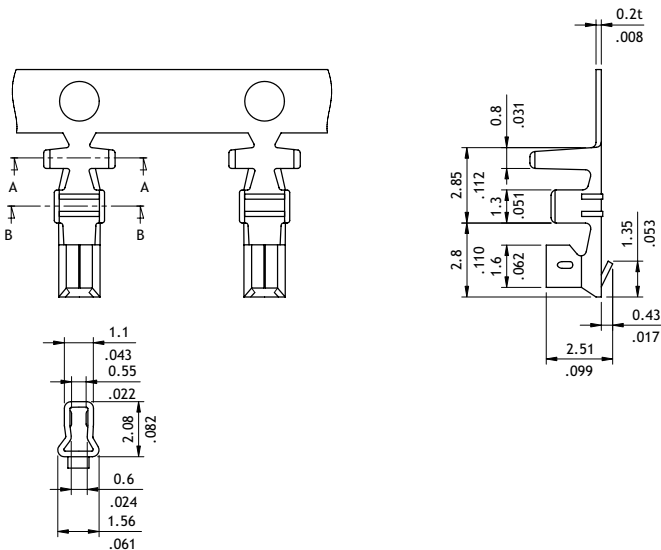

Wire Range	Insulation Diameter	Reel Qty
AWG #24-#28	1.9 (.075) MAX.	10,000 PCS.

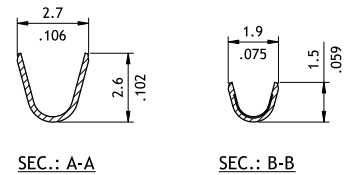

Ordering Code

① CI 21 **② 1 5** **③ S** **④ 0 0 0 0**

- ① Series No.
- ② No. of Circuits: 02 to 15
- ③ S = Housing
- ④ Other Options:
0000 = Standard
*Special options consult manufacturer

① CI 21 **② T 0 2** **③ 1** **④ P** **⑤ E 0**

- ① Series No.
- ② Type: T02 = AWG #24 ~ #28
- ③ Plating Code: 1 = Tin over Nickel
- ④ Material: P = Phosphor Bronze
- ⑤ Other Options: E0 = Standard