

A-A SEC.

B-B SEC.

(Available in 4 through 8 circuits)

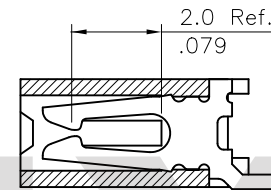
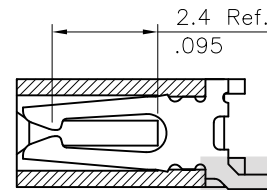

A-A SEC.

B-B SEC.

(Available in 9 through 32 circuits)

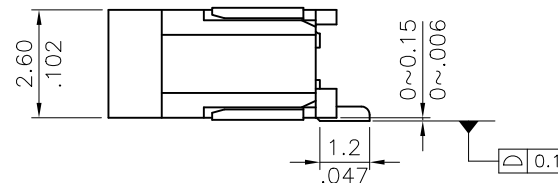
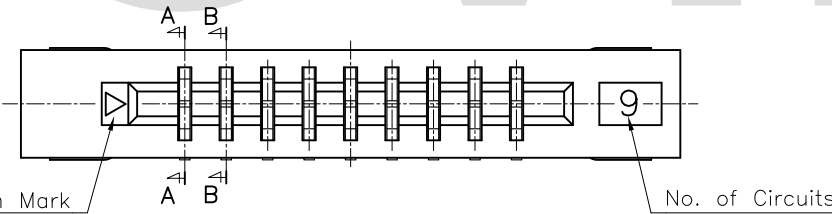

Halogen-Free

Lead Free Process

RoHS Compliant

4						DATE	UNIT: mm / inch	TITLE: 1.00mm(.039") LIF FPC/FFC SURFACE MOUNT CONNECTOR		 瀚荃股份有限公司 CviLux Corporation	
3			DRAWN BY: Enya		10/18-13'	TOLERANCE UNLESS OTHERWISE SPECIFIED					
2			ENGINEER: Sun		10/22-13'	.X ± 0.15/.006	X' ± 1'	MATERIAL:			
1	Enya	10/18-13'	ECNT113069		CHECKED BY: Eisley	10/24-13'	.XX ± 0.10/.004	.X' ±	FINISH:		
SYM	NAME	DATE	REVISIONS	APPROVED BY: Eisley	10/24-13'	.XXX ± 0.05/.002	.XX' ±	DRAWING NO. CF0822SB	PART NO. CF08**1H2*0-NH	SCALE 5 / 1	SHEET 1 OF 3



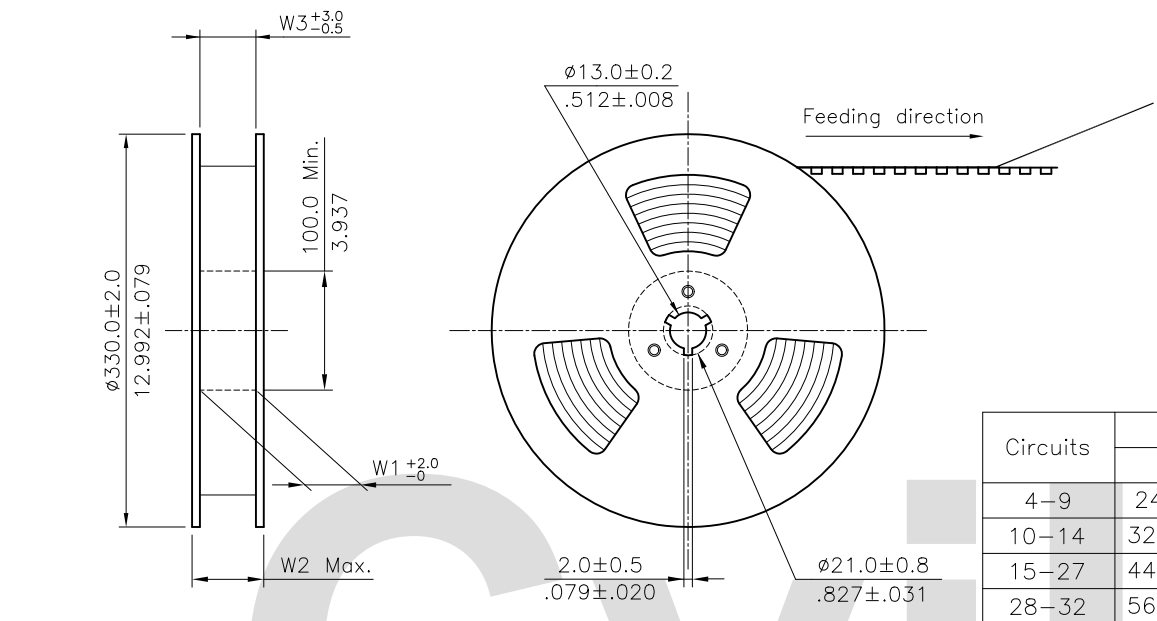

NOTE :

- \* Reel Material : HIPS or Corrugated Paper
- \* Carrier Material : Clear Conductive Polystyrene Alloy
- \* Cover Tape Material : Polyester
- \* Cover Tape Peel Strength : 0.1N – 1.3N
- \* Carrier camber is within 1mm in 100mm
- \* All dimensions meet EIA-481-2 & EIA-481-3 requirements.
- \* Quantity : 2000 PCS/Reel

Circuits	Dimension					Packing (Reel/Carton)
	E	F	W1	W2	W3	
4-9	24.0(.945)	-	24.5(.965)	30.5(1.201)	24.5(.965)	9
10-14	32.0(1.260)	28.40(1.118)	32.5(1.280)	38.5(1.516)	32.5(1.280)	7
15-27	44.0(1.732)	40.40(1.591)	44.5(1.752)	50.5(1.988)	44.5(1.752)	5
28-32	56.0(2.205)	52.40(2.063)	56.5(2.224)	62.5(2.460)	56.5(2.224)	4

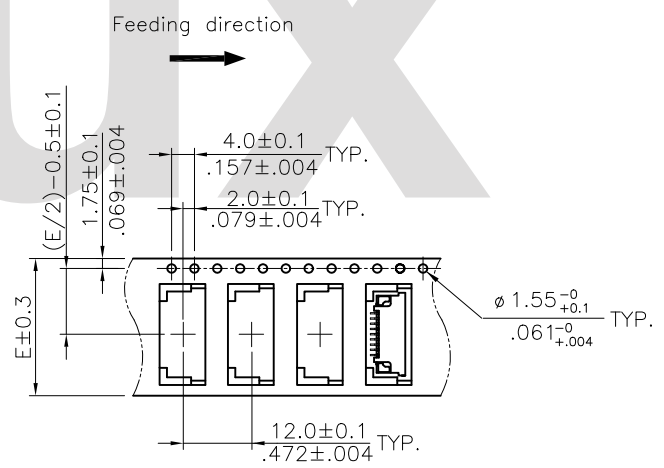
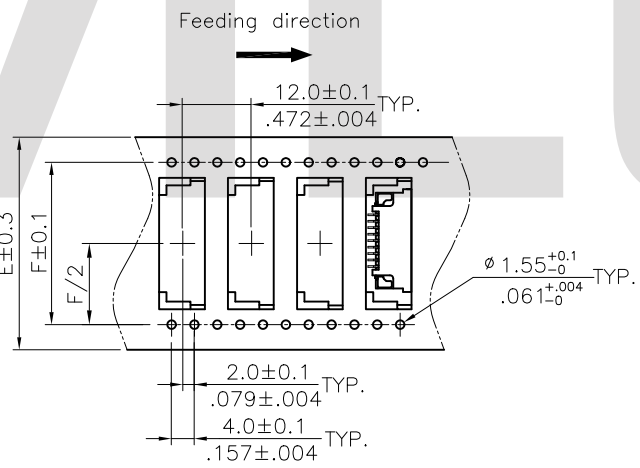
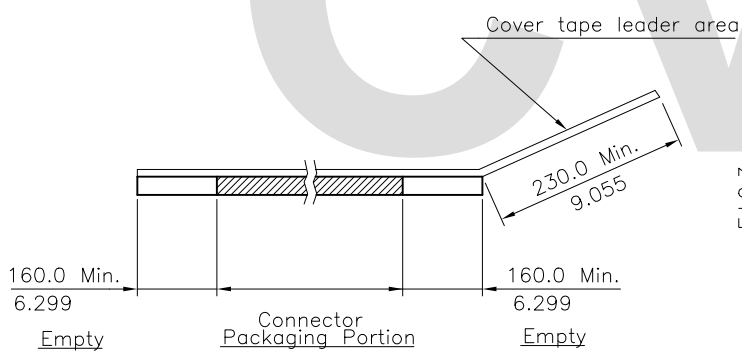

WIDTH : 32,44,56 mm Carrier

WIDTH : 24 mm Carrier

RoHS Compliant

4	Enya	10/18-13'	ECNT113069	CVILUX CORP 2013.11.07 ISSUED	DRAWN BY: Enya	10/18-13'	UNIT: mm / inch	TITLE: 1.00mm(.039") LIF FPC/FFC SURFACE MOUNT CONNECTOR	MATERIAL:	FINISH:	DRAWING NO. CF0822SB	PART NO. CF08**1H2*0-NH	SHEET 3 OF 3					
														3	ENGINEER: Sun	10/22-13'	TOLERANCE UNLESS OTHERWISE SPECIFIED	SCALE
														2	CHECKED BY: Eisley	10/24-13'	.X ±      .X' ± 1'	
														1	APPROVED BY: Eisley	10/24-13'	.XX ±     .X' ±	
SYM	NAME	DATE	REVISIONS		APPROVED BY:													

