

Notes :

- * Applicable Cable : (O.D. must be less than 0.4mm)
- Coaxial Cable : AWG #36~#42
- Wire Cable : AWG #32

Material :

- * Base : High temperature plastic UL 94V-0, Color Black
- * Contact : Copper Alloy
- * Inner Shell : Copper Alloy
- * Outer Shell : Stainless Steel, Cleaning

Plating :

- * Contact: Contact area is plated gold and other area is plated with gold flash, over all Nickel 40μ" Min. under plated.
- * Inner shell: Clenaing or plated matt tin 80μ" Min. over all Nickel 40μ" Min. under plated

Ordering Code

CVS2 ** * P 1 T0 -NH
 ① ② ③ ④ ⑤ ⑥ ⑦

- ① Series No.
- ② No. of Circuits
- ③ Plating code:
 2= Gold flash plated
 W= Selevtive 0.08μm(3μ") Gold plated on contact area
 D= Selevtive 0.13μm(5μ") Gold plated on contact area
 E= Selevtive 0.25μm(10μ") Gold plated on contact area
 F= Selevtive 0.38μm(15μ") Gold plated on contact area
- ④ Contact style: P= PLUG
- ⑤ Color: 1= Black
- ⑥ Packing: T0= Tube Packing
- ⑦ Other option:
 NH= For Lead Free IR Processes and Halogen-Free

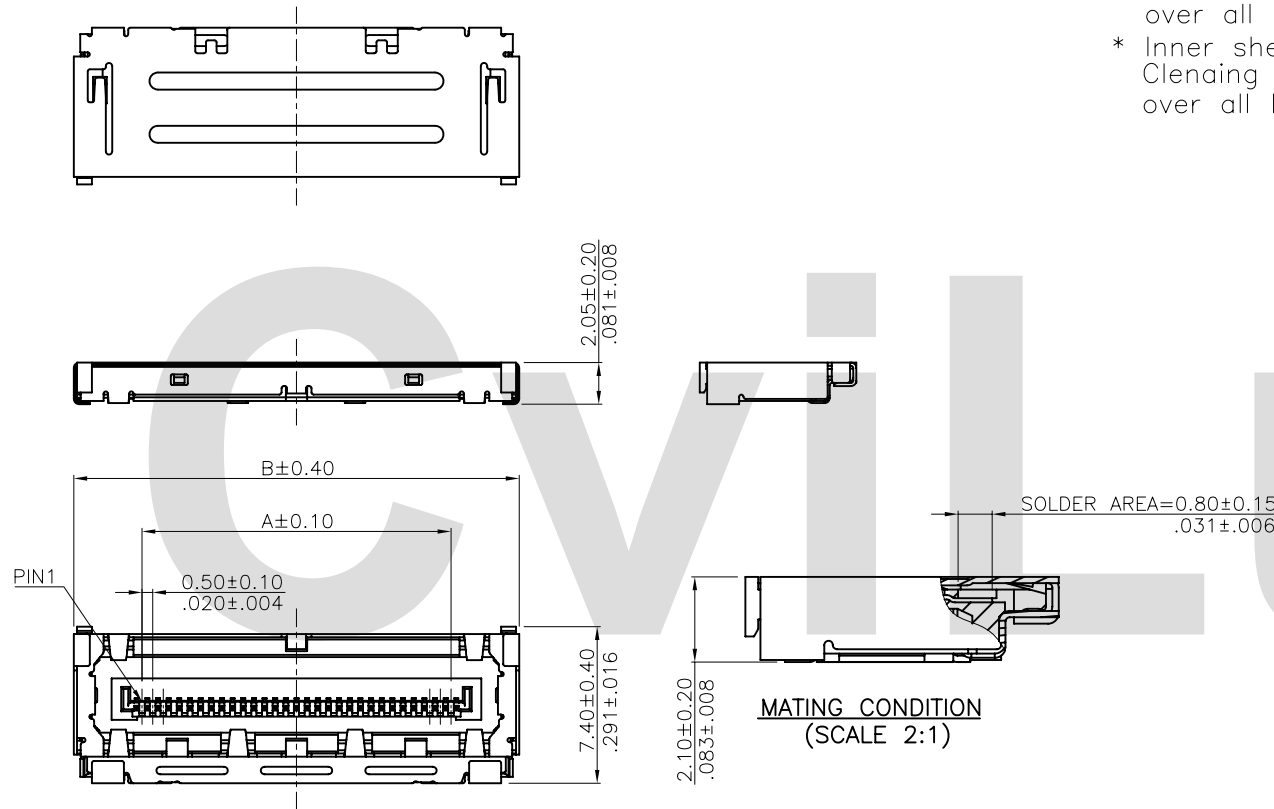

NO. of contacts (n)	Dimensions	
	A	B
30	14.50(.571)	21.10(.831)
40	19.50(.768)	26.00(1.024)

Halogen-Free Lead Free Process RoHS compliant

4					DATE	UNIT: mm / inch	TITLE: 0.50mm(.020") LVDS PLUG CONNECTOR M/H 2.0	瀚荃股份有限公司 CviLux Corporation
3					2014.10.03	TOLERANCE UNLESS OTHERWISE SPECIFIED	MATERIAL:	
2					ISSUED		FINISH:	DRAWING NO. CVS201SB
1	Claire	2014 0930	ECRT214033/ECNT214051	CHECKED BY: Jerry	10/1-14"	.X ± 0.25/.010 X' ±		PART NO. CVS2***P1T0-NH
SYM	NAME	DATE	REVISIONS	APPROVED BY: Scott	10/1-14"	.XX ± 0.15/.006 X' ± 1'		SCALE 4 / 1
						.XXX ± .XX ±		SHEET 1 OF 3

Ordering Code

CVS2 ** * P000 -NH
 ① ② ③ ④ ⑤

- ① Series No.
- ② No. of Circuits
- ③ Plating code:
See the page 1
- ④ Contact style: P000= PLUG
- ⑤ Other option:
NH= For Lead Free IR Processes and Halogen-Free

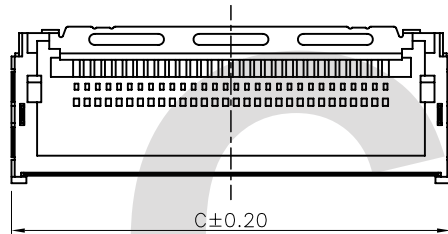
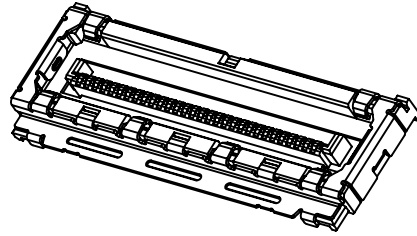

NO. of contacts (n)	Dimensions	
	A	C
30	14.50(.571)	20.60(.811)
40	19.50(.768)	25.60(1.008)

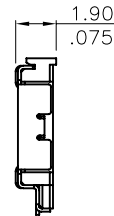
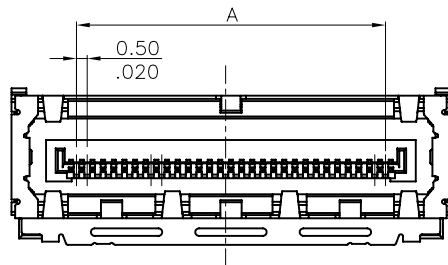

Ordering Code

CVS2 ** A S000
 ① ② ③ ④

- ① Series No.
- ② No. of Circuits
- ③ Plating code: A= Non Plated
- ④ Material: S000= Shell

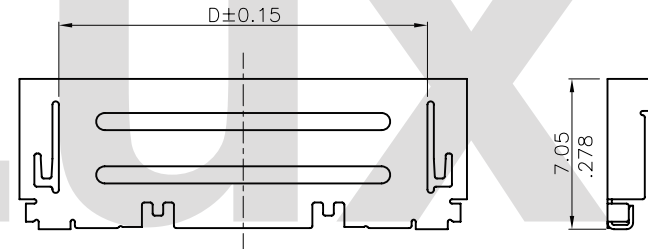

NO. of contacts (n)	Dimensions	
	B	D
30	21.10(.831)	17.30(.681)
40	26.00(1.024)	22.30(.878)

Halogen-Free

Lead Free Process

RoHS Compliant

CVILUX CORP
 2014.10.03
 ISSUED

④					DATE	UNIT: mm / inch	TITLE: 0.50mm(.020") LVDS PLUG CONNECTOR M/H 2.0	瀚荃股份有限公司 CviLux Corporation				
③				DRAWN BY:	Claire	10/1-14"	TOLERANCE UNLESS OTHERWISE SPECIFIED	MATERIAL:	DRAWING NO.	CVS201SB	PART NO.	CVS2***P000-NH CVS2***AS000
②				ENGINEER:	Francis	10/1-14"		.X ± 0.25/.010	.X* ±	SCALE	4 / 1	SHEET
①	Claire	2014 09/30	ECRT214033/ECNT214051	CHECKED BY:	Jerry	10/1-14"	.XX ± 0.15/.006	.X* ± 1"	FINISH:			
SYM	NAME	DATE	REVISIONS	APPROVED BY:	Scott	10/1-14"	.XXX ±	.XX* ±				

PACKING CAPACITY(SEMI-FINISHED GOODS)			
CIRCUITS	PCS/TUBE	TUBE/CARTON	PCS/CARTON
30	25PCS/TUBE	500TUBE/CARTON	12500PCS/CARTON
40	20PCS/TUBE	600TUBE/CARTON	12000PCS/CARTON

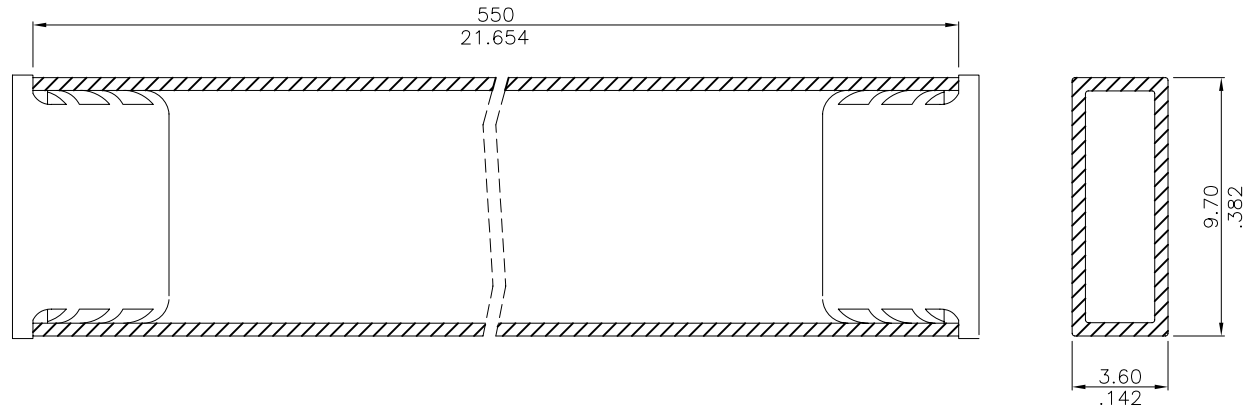

DIMENSION	
PART NAME	DIM.(LxWxH)
CARTON 1	560X220X180
CARTON 2	590X410X220

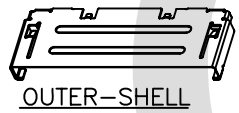

OUTER-SHELL

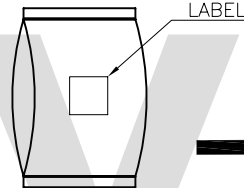

1K PCS IN EACH BAG

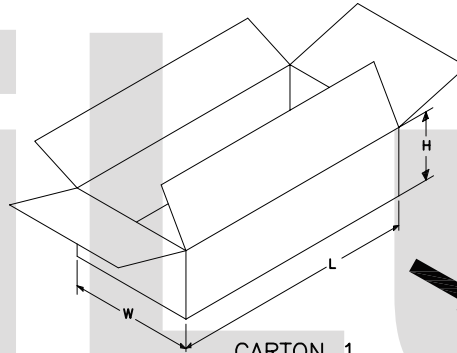

CARTON 1

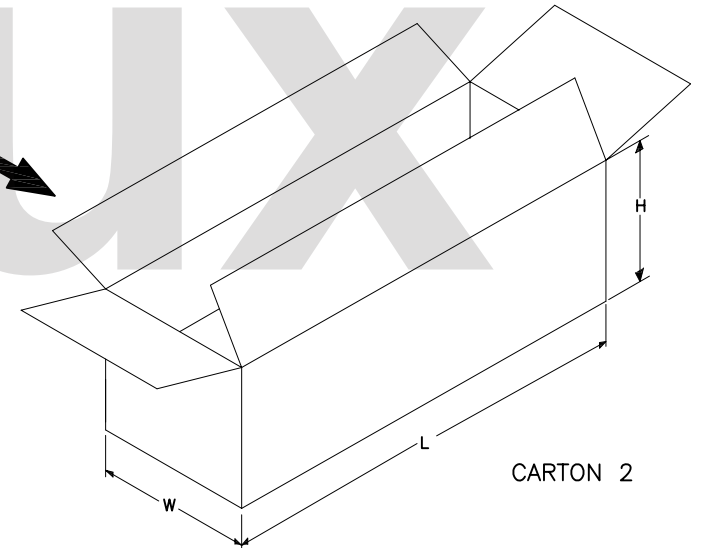

CARTON 2

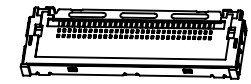

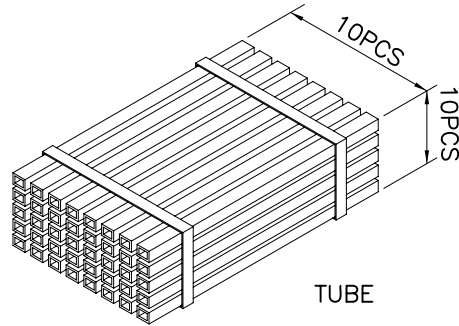

SEMI-FINISHED GOODS



TUBE



RoHS Compliant

4				 2014.10.03 ISSUED		DATE	UNIT: mm / inch	TITLE: 0.50mm(.020") LVDS PLUG CONNECTOR M/H 2.0	 瀚荃股份有限公司 CviLux Corporation
3			DRAWN BY: Claire		10/1-14"	TOLERANCE UNLESS OTHERWISE SPECIFIED	MATERIAL:		
2			ENGINEER: Francis		10/1-14"	.X ± 0.15/.006 X' ±	FINISH:		
1	Claire	2014 0930	ECRT214033/ECNT214051		CHECKED BY: Jerry	10/1-14"		.XX ± 0.10/.004 X' ± 1'	DRAWING NO. CVS201SB
SYM	NAME	DATE	REVISIONS	APPROVED BY: Scott	10/1-14"	.XXX ± .XX ±	SCALE	4 / 1	SHEET 3 OF 3