

A = 1.00 * No. of Spaces
 B = A + 8.0
 C = A + 2.1

* Available in 4 through 32 circuits

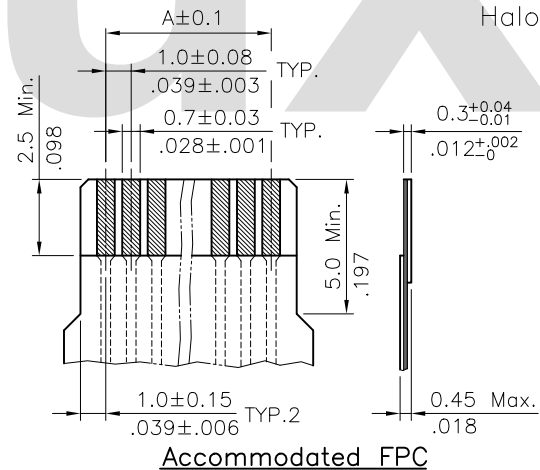
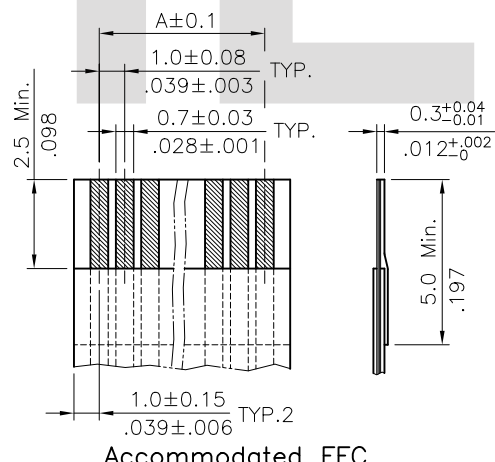
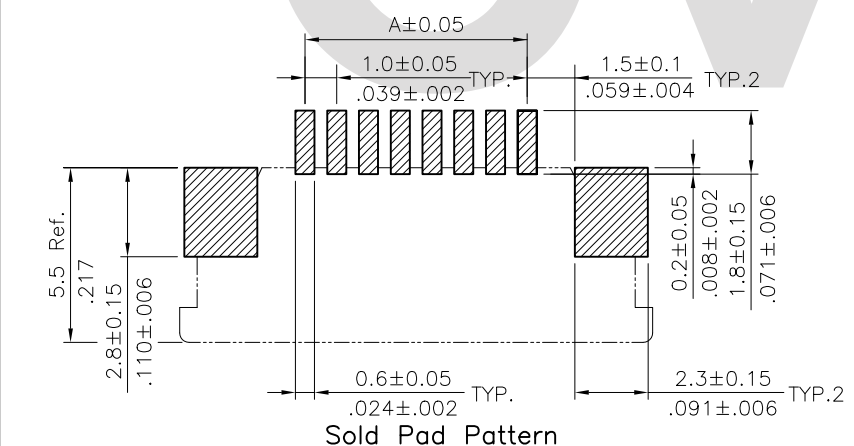
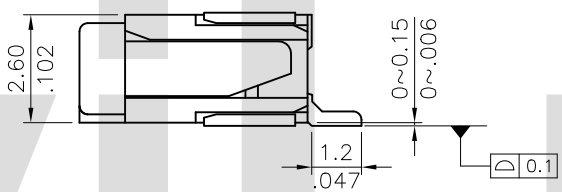
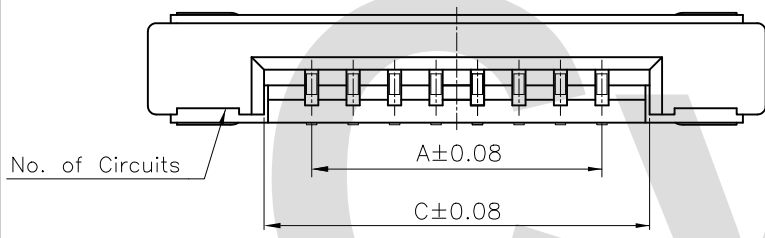
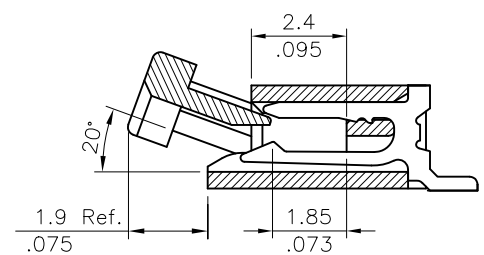

Material :
 * Body : High Temperature plastic UL 94V-0
 * Slider : High Temperature plastic UL 94V-0 Color Black
 * Contact : Copper Alloy with Matte Tin plated
 * Fixed tab : Copper Alloy with Matte Tin plated

Ordering Code

CF07 ** 1 D 0 * 0 -NH
 ① ② ③ ④ ⑤ ⑥ ⑦ ⑧

- ① Series No.
- ② No. of Circuits
- ③ Plating code:
1 = Matte Tin plated over Nickel
- ④ Contact style: D = Downside Contact
- ⑤ Color: 0 = Nature
- ⑥ Packing options: R = Tape & Reel
T = Tube Packing
- ⑦ Other options: 0 = Standard
- ⑧ Process options: -NH = For Lead Free IR Processes and Halogen-Free

Halogen-Free
 Lead Free Process
 RoHS Compliant

④					DATE	UNIT: mm / inch	TITLE: 1.00mm(.039") ZIF FPC/FFC DOWNSIDE CONTACT SURFACE MOUNT CONNECTOR	瀚荃股份有限公司 CviLux Corporation
③	Enya	10/18-13'	ECNT113069	DRAWN BY:	Enya	10/18-13'	MATERIAL:	
②	Una	8/17-11'	ECN11184	ENGINEER:	Sun	10/22-13'	FINISH:	DRAWING NO. CF0732SD
①	Sun	9/10-08'	ECR08047-2/ECN08398	CHECKED BY:	Eisley	10/24-13'		PART NO. CF07**1D0*0-NH
SYM	NAME	DATE	REVISIONS	APPROVED BY:	Eisley	10/24-13'		SCALE 5 / 1
								SHEET 1 OF 2

CVILUX CORP
 2013.11.07
 ISSUED

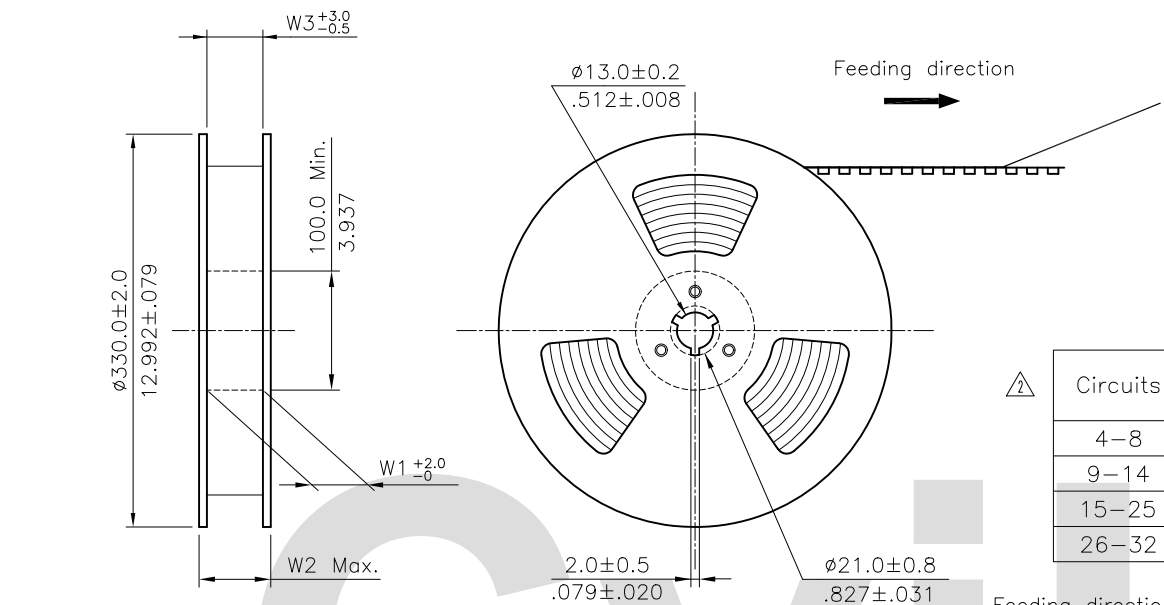

NOTE :

1. 10 sprocket hole pitch cumulative tolerance ± 0.20
2. Carrier camber is within 1 mm in 100 mm .
- △ 3. Material : Transparent Conductive Polystyrene Alloy (UP-5000) 100% recyclable.
4. All dimensions meet EIA-481-3 requirements.
5. Thickness : 0.33 ± 0.03 mm.
- 6 Packing length per 22" reel : 75.0 Meters.
7. Component load per 13" reel : 2000 pcs.

Circuits	Dimension				
	E	F	W1	W2	W3
4-8	24.0(.945)	-	24.5(.965)	30.5(1.201)	24.5(.965)
9-14	32.0(1.260)	28.40(1.118)	32.5(1.280)	38.5(1.516)	32.5(1.280)
15-25	44.0(1.732)	40.40(1.596)	44.5(1.752)	50.5(1.988)	44.5(1.752)
26-32	56.0(2.205)	52.40(2.062)	56.5(2.224)	62.5(2.460)	56.5(2.224)

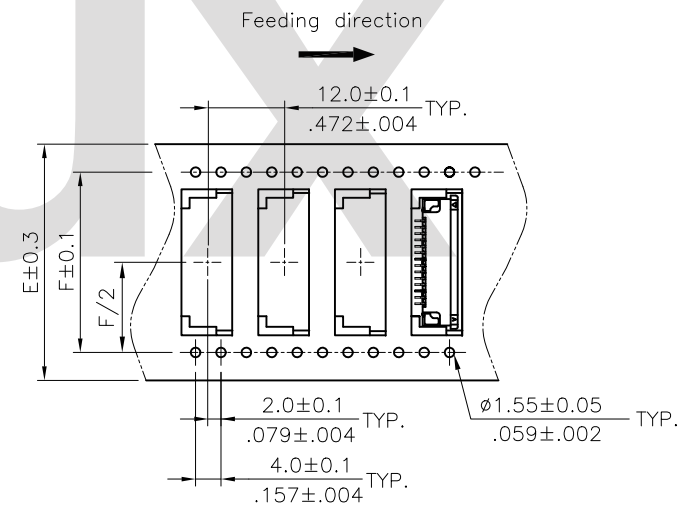
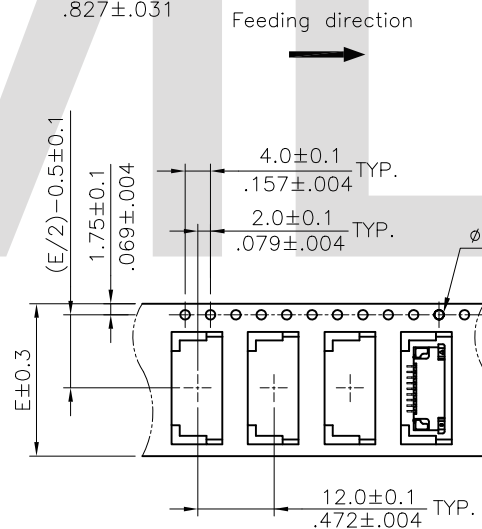
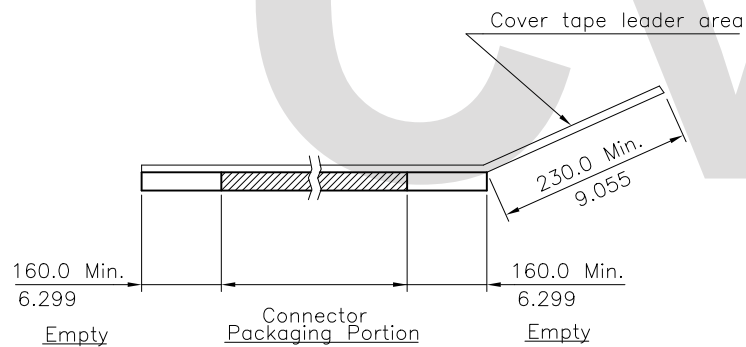

△ 3 WIDTH : 24 mm Carrier

WIDTH : 32,44,56 mm Carrier

RoHS Compliant

SYM	NAME	DATE	REVISIONS	APPROVED BY:	DATE	UNIT: mm / inch	TITLE: 1.00mm(.039") ZIF FPC/FFC DOWNSIDE CONTACT SURFACE MOUNT CONNECTOR	MATERIAL:	FINISH:	DRAWING NO.	PART NO.	SHEET	OF	
4														
3	Enya	10/18-13'	ECN113069	DRAWN BY:	Enya	10/18-13'	TOLERANCE UNLESS OTHERWISE SPECIFIED			CF0732SD	CF07**1D0*0-NH	2	OF	2
2	Una	8/17-11'	ECN11184	ENGINEER:	Sun	10/22-13'								
1	Sun	9/10-08'	ECR08047-2/ECN08398	CHECKED BY:	Eisley	10/24-13'								
				APPROVED BY:	Eisley	10/24-13'								
						.X ±	X' ± 1'							
						.XX ±	.X ±							
						.XXX ±	.XX ±							

