

No.	DESCRIPTION	MATERIAL	FINISH	Q'TY
1	BODY	BRASS	GOLD PLATED	1
2	INSULATOR	TEFLON	-	1
3	CONTACT	BRASS	GOLD PLATED	1

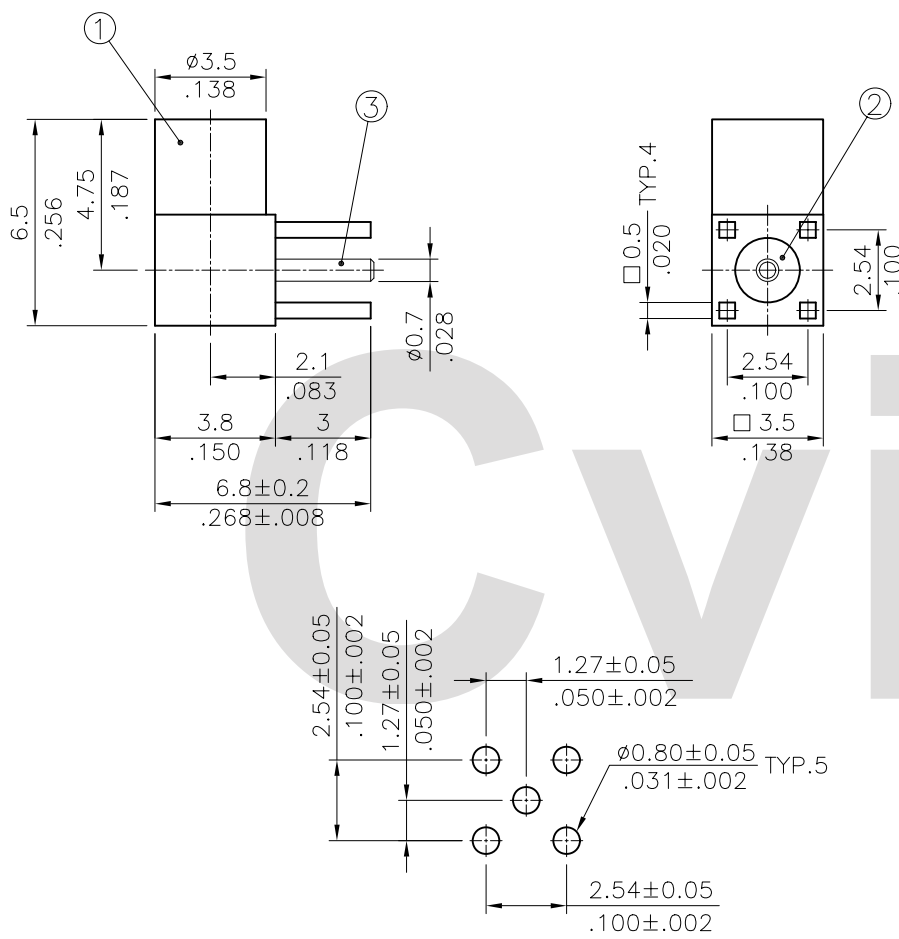

Recommended P.C. Board Layout

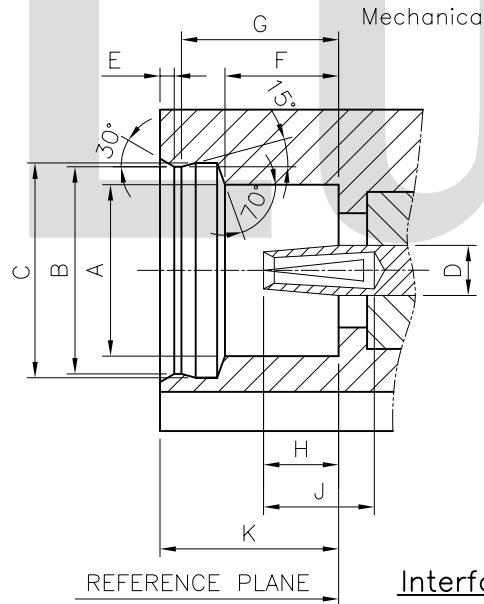

REFERENCE PLANE

Interface Mating Dimensions

DIM.	Min.	Max.
A	2.41(.095)	-
B	2.87(.113)	2.90(.114)
C	3.00(.118)	3.04(.120)
D	0.68(.026)	0.72(.028)
E	-	0.23(.009)
F	1.57(.062)	1.63(.064)
G	2.30(.091)	2.34(.092)
H	0.90(.035)	1.20(.047)
J	1.40(.055)	-
K	2.60(.102)	-

Specifications:

Electrical

- Impedance: 50Ω
- Frequency Range: 0-6 GHz
- Working Voltage: 170 VRMS Max.
- Dielectric Withstanding Voltage: 500 VRMS Min.
- VSWR: 1.3 Max.
- Contact Resistance
 - Center contact: 5mΩ Max.
 - Outer Contact: 2.5mΩ Max.
- Insulator Resistance: 1000MΩ Min.

Mechanical & Environmental

- Engagement Force: 3.4 lbs. Max.
- Disengagement Force: 1.4-3.4 lbs.
- Contact Retention: 2.3 lbs. Min.
- Durability (Mating): 500 cycles Min.
- Temperature Range: -65°C to 155°C
- Vibration: 3 cycles, 3 opposite directions, 10-150 Hz
 - 10-60 Hz: 0.75mm/0.030 in., 60-150 Hz 10G's
- Thermal Shock: MIL-STD-202 Method 107
- Humidity: MIL-STD-202 Method 103 Test Cond.B
- Mechanical Shock: MIL-STD-202 Method 213 Test Cond.B

SYM	NAME	DATE	REVISIONS	APPROVED BY:	DATE	UNIT: mm / inch	TOLERANCE UNLESS OTHERWISE SPECIFIED
④							
③							
②							
①							
						X: ±0.50/.020	X' ± 1'
						X ±0.30/.012	X' ±
						.XX ±0.15/.006	.XX' ±



TITLE: MMCX SERIES RIGHT ANGLE
PCB MOUNT TYPE JACK CONN.
MATERIAL:
FINISH:



DRAWING NO.	CR0402SA	PART NO.	CR04S04225000
SCALE	4 / 1	SHEET	1 OF 1

RoHS Compliant