

No.	DESCRIPTION	MATERIAL	FINISH	Q'TY
1	CONTACT	BRASS	GOLD PLATED	1
2	INSULATOR	TEFLON	-	1
3	BODY	BRASS	GOLD PLATED	1
4	INSULATOR	TEFLON	-	1

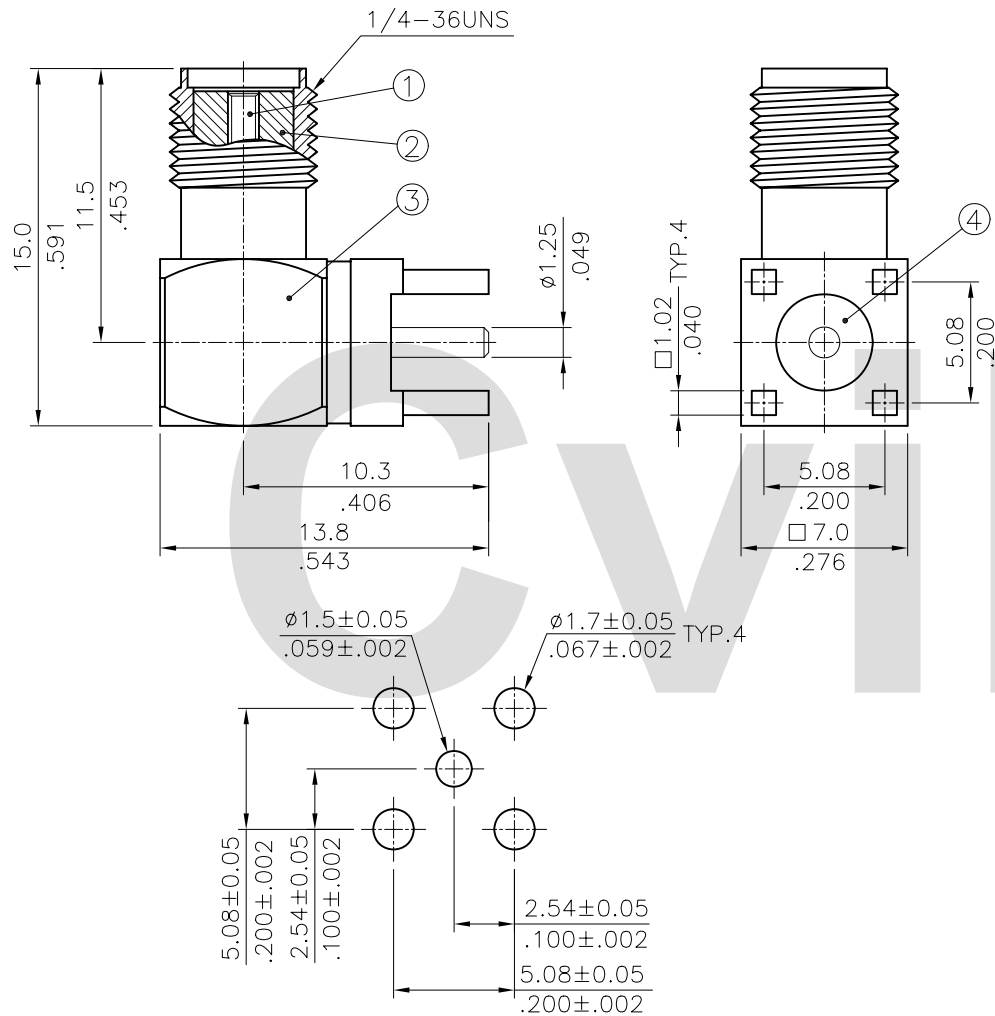

Specifications:

Electrical

Impedance: 50Ω

Frequency Range

0-12.4 GHz on Flexible cable

0-18.0 GHz on Semi-rigid cable

Working Voltage: 250 VRMS Max.

Dielectric Withstanding Voltage: 750 VRMS Min.

VSWR: 1.5 Max.

Contact Resistance

Center contact: 6mΩ Max.

Outer Contact: 2mΩ Max.

Insulator Resistance: 5000MΩ Min.

Mechanical & Environmental

Engagement Force: 2 in-lbs. Max.

Disengagement Force: 2 in-lbs. Max.

Coupling Nut Retention: 60 lbs. Min.

Coupling Proof Retention: 15 in-lbs. Min.

Contact Retention: 6 lbs. Min.

Durability (Mating): 500 cycles Min.

Temperature Range: -65°C to 165°C

Vibration: MIL-STD-202 Method 204 Test Cond.B

Salt Spray: MIL-STD-202 Method 101 Test Cond.B

Thermal Shock: MIL-STD-202 Method 107 Test Cond.B

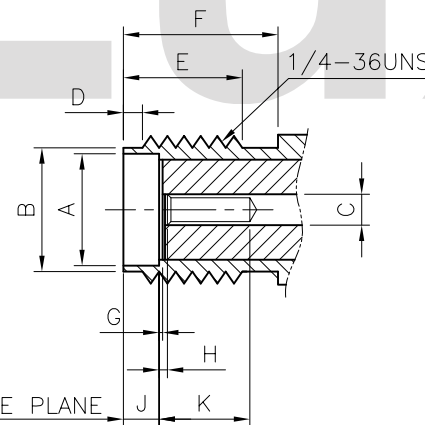

DIM.	Min.	Max.
A	4.60(.181)	4.67(.184)
B	5.28(.208)	5.49(.216)
C	1.24(.049)	1.30(.051)
D	0.38(.015)	1.14(.045)
E	4.32(.170)	-
F	5.54(.218)	-
G	0.00	0.25(.010)
H	0.00	0.25(.010)
J	1.88(.074)	1.98(.078)
K	2.92(.115)	-

Recommended P.C. Board Layout

Interface Mating Dimensions

RoHS Compliant

SYM	NAME	DATE	REVISIONS	APPROVED BY:	DATE	UNIT: mm / inch	TITLE: SMA SERIES RIGHT ANGLE PCB MOUNT TYPE JACK CONN.	MATERIAL:	FINISH:	DRAWING NO.	PART NO.	SHEET	OF
4													
3													
2													
1													



DRAWING NO.	CR0105SA	PART NO.	CR01S04225000
SCALE	3 / 1	SHEET	1 OF 1